

TOSHIBA

**A Quality Product
for World Energy**

INSTRUCTIONS:

Installation and Maintenance For 50 & 60 Hertz Motors

Toshiba World Energy Motors
Polyphase motors

- Frames 143T through 507UZ
Dripproof
- Frames 143T through N587UZ
Totally-Enclosed Fan-Cooled
- Frames 143T through 447TZ
Explosion- Proof.

STORAGE

- (1) Store motor in a clean, dry and cover completely with (Leave opening for ventilation)
- (2) Motor must be thoroughly dry before applying power.
- (3) Every six months, give winding a megger test. A minimum of 10 megohms are recommended.
- (4) Also, every six months, rotate shaft and add grease as needed.

READ CAREFULLY BEFORE INSTALLING AND STARTING RECEIVING"

- (1) Check nameplate
- (2) Check whether any damage has occurred during transportation. (Motors are normally shipped F.O.B. factory. Freight claims must be submitted by the consignee to the carrier.)
- (3) When supplied -Be sure to remove bearing lock plate before start-up.
- (4) Turn shaft by hand to check that it turns freely.

LOCATION

- (1) All motors should be located in an area where ventilation is not restricted and affects the operation of the motor.
- (2) Dripproof Motors are designed for installation in a well ventilated place where the atmosphere is reasonably free of dirt and moisture.
- (3) Totally enclosed motors may be installed where dirt, moisture (not running water) and corrosion are present, or in outdoor locations.
- (4) Explosion Proof motors are designed and built for hazardous duty.
Listed by U L for Class 1, Group D; and Class 11, Groups E, F and G. Also listed by C S A.

MOUNTING

- (1) Mount motor securely on a firm, flat base. All ball and roller bearing normal thrust motors may be mounted in any position.
- (2) Align motor accurately, using a flexible coupling if possible. For drive recommendations consult with drive or equipment manufacturer, or Toshiba. See additional information on pages 3 and 4.
- (3) V-belt Sheave Pitch Diameters should not be less than the following Table 1, values (NEMA recommended values).
- (4) Tighten belts only enough to prevent slippage. Belt speed should not exceed 5000 ft. per min.
- (5) Motors must not be subjected to vibration exceeding 0.5 G force.
(Motors should not be mounted to shaker screens)

POWER SUPPLY & CONNECTIONS

- (1) Nameplate voltage and frequency should agree with power supply. Motor will operate satisfactorily on line voltage within 10% of nameplate value; or frequency within 5%; combined variation not to exceed 10%. 230 Volt motors can be used on 208-volt network systems, but with slightly modified performance characteristics.
- (2) Dual voltage and single voltage motors can be connected for the desired voltage by following connection diagram shown on nameplate. Alternate starting connections are shown in the conduit box or connection diagrams on pages 5 and 6.
- (3) Explosion Proof motors have Temperature Limiting Devices in the motor enclosure to prevent excessive external surface temperature of the motor in accordance with U L standards. Terminals of thermal protectors (P1, P2) should be connected to the motor control equipment.
- (4) Wiring of motor and control, overload protection and grounding should be in accordance with National Electrical Code and local building codes.
- (5) Disconnect motor from power supply before opening conduit box or working on motor.
- (6) Megger test before energizing. A minimum of 10 megohms are recommended.

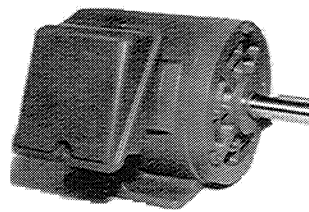

ODP Frames 143T-256T

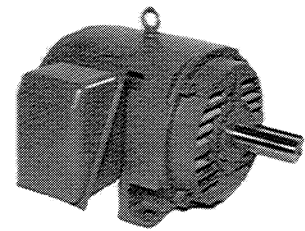

ODP Frames 404T-507UZ

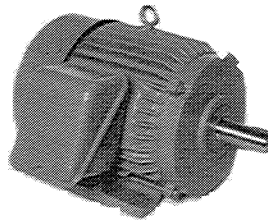

TEFC Frames 143T-256T

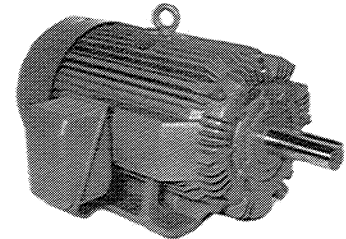

TEFC Frames 444T-N587UZ

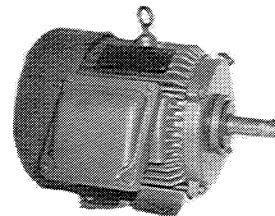

XP Frames 143T-256T

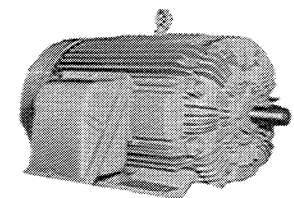

XP Frames 404T-447TZ

Table 1. V-belt Sheave Pitch Diameters (MG 1 -14.42)

Frame No.	Horsepower at Speed Range			V-belt Sheave (inches)			
	2 Pole	4 Pole	6 Pole	Conventional A, B, C, D and E		Narrow 3V, 5V and 8V	
				Min. Pitch Diameter	Max Width*	Min. Outside Diameter	Max Width**
143T	1 1/2	1	3/4	2.2	4.250	2.2	2.250
145	2-3	1 1/2 - 2	1	2.4	4.250	2.4	2.250
182T	3	3	1 1/2	2.4	5.250	2.4	2.750
182T	5	-	-	2.6	5.250	2.4	2.750
184T	-	-	2	2.4	5.250	2.4	2.750
184T	5	-	-	2.6	5.250	2.4	2.750
184T	7 1/2	5	-	3.0	5.250	3.0	2.750
213T	7 1/2 - 10	7 1/2	3	3.0	6.500	3.0	3.750
215T	10	-	5	3.0	6.500	3.0	3.750
215T	15	10	-	3.8	6.500	3.8	3.750
254T	15	-	7 1/2	3.8	7.750	3.8	4.000
254T	20	15	-	4.4	7.750	4.4	4.000
256T	20 - 25	-	10	4.4	7.750	4.4	4.000
256T	-	20	-	4.6	7.750	4.4	4.000
284T	-	-	15	4.6	9.000	4.4	4.250
284T	-	25	-	5.0	9.000	4.4	4.250
286T	-	30	20	5.4	9.000	5.2	4.250
324T	-	40	25	6.0	10.250	6.0	5.250
326T	-	50	30	6.8	10.250	6.8	5.250
364T	-	-	40	6.8	11.500	6.8	5.250
364T	-	60	-	7.4	11.500	7.4	5.250
365T	-	-	50	8.2	11.500	8.2	5.500
365T	-	75	-	9.0	11.500	8.6	5.500
404T	-	-	60	9.0	14.250	8.0	7.250
404T	-	100	-	10.0	14.250	8.6	7.250
405T	-	-	75	10.0	14.250	10.0	7.250
405T	-	100	-	10.0	14.250	8.6	7.250
405T	-	125	-	11.5	14.250	id.5	7.250
444T	-	-	100	11.0	16.750	10.0	8.500
444T	-	125	-	11.0	16.750	9.5	8.500
444T	-	150	-	-	-	10.5	8.500
445T	-	-	125	12.5	16.75.0	12.0	8.500
445T	-	150	-	-	-	10.5	8.500
445T	-	200	-	-	-	13.2	8.500

* Max sheave width - 2 (N-W)-1/4". **Max. sheave width = N-W.

Sheave ratios greater than 8:1 and center-to-center distance less than the diameter of the large sheave should be referred to the company. Sheaves must be mounted close to the shaft shoulder.

Fig. 1 SHAFT EXTENSION LOADS DUE TO TRANSMISSION OF POWER

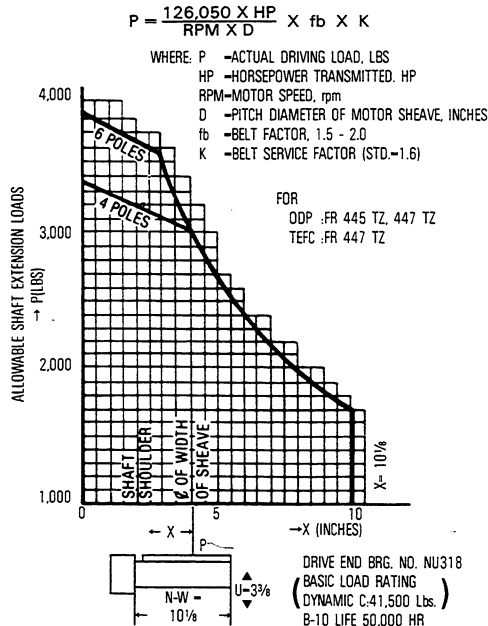
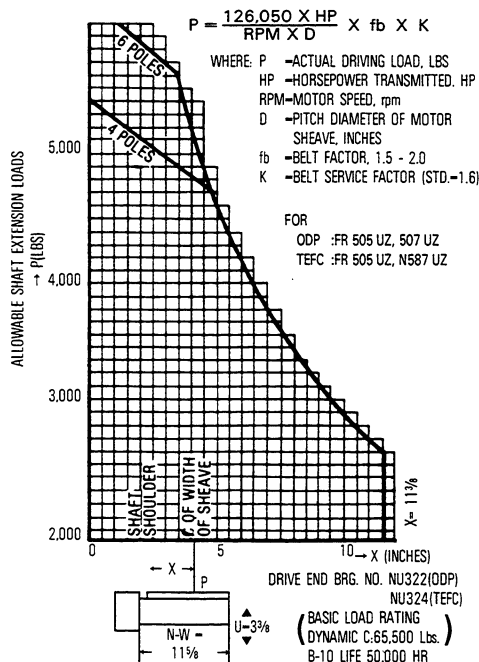

Fig. 2 SHAFT EXTENSION LOADS DUE TO TRANSMISSION OF POWER



ALIGNMENT PROCEDURES

MOTOR LEVELING & COUPLING ALIGNMENT

When the base has been adjusted, leveled, and grouted, the correct motor leveling and coupling alignment are obtained with the aid of shims between the motor and the base. To give the motor proper support, it is important that the base and shims extend under the motor.

RIGID COUPLING

Extreme care must be taken to obtain correct alignment when using rigid couplings. Circular concentric peripheral surfaces of the two coupling halves must indicate correct alignment within 0.0005 in. to 0.001 in. when the two coupling halves are rotated together. The separation between the faces of the two coupling halves must also be maintained within the same tolerance.

The alignment may be checked by utilizing a dial indicator as shown in Fig. 3 or with the aid of a straight-edge and thickness gauge or feelers as shown in Fig. 4.

The preferred method of checking alignment is with the dial indicator. Bolt the indicator to one of the coupling halves and indicate the position of the dial button on the opposite coupling half with a chalk mark. Set the indicator dial to zero at the first position and then rotate both halves of the coupling to a new position where a check reading is to be made. All readings must be made with the dial button located at the chalk mark, and not less than six different sets of readings should be taken. A variation in the dial reading at different positions of coupling rotation will indicate whether the machine has to be raised, lowered, or moved to one side or another to obtain alignment of the circular concentric peripheral surfaces of the two coupling halves within the specified tolerance.

In addition to the above check, a check of the separation of the coupling faces must be made to establish correct alignment. The separation between the faces of the coupling may be checked with a dial indicator fastened

to one coupling half and a reference surface fastened to the other coupling half. Mark the location of the dial button on the reference surface and make all readings with the indicator in this position. Set the dial of the indicator to zero for the first reading and use this as the reference. Be sure to rotate both halves of the coupling the same amount, aligning the button of the indicator and the mark on the reference surface for each of six readings. A variation of the readings at different positions will indicate how the machine has to be adjusted to obtain correct alignment. After each adjustment of the motor, repeat the above procedure to be certain that correct alignment and leveling have been obtained.

FLEXIBLE COUPLING

Units coupled through flexible couplings should be aligned as accurately as possible. As a suggested limit, the two halves should indicate correct alignment within 0.002 in. on both the circular concentric peripheral surfaces and the separation between faces. Although most flexible couplings will withstand greater misalignment than rigid couplings, extreme misalignment can cause vibration possibly resulting in failure of motor bearings and/or shaft.

If the method shown in Fig. 4 is used to check alignment of the machines, correct alignment exists -- if the peripheries of the coupling halves are true circles of the same diameter and if the faces are flat -- when the separation between the faces is held to within the specified tolerance at all points and a straight-edge lies squarely across the rims at any point. Non-parallel faces will be indicated by a variation in separation of the coupling halves as they are rotated, and a difference in height of the coupling halves will be indicated by the straight-edge and feeler gauge test.

When the coupling halves have been correctly aligned with the motor feet bolted in position, place temporary bolts in two coupling holes for clamping the halves together. Then, ream for a light drive fit through bolt holes for regular coupling bolts.

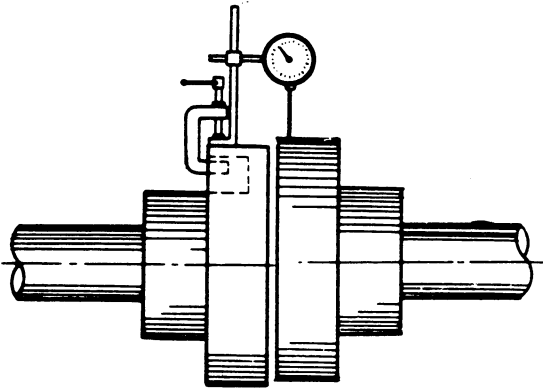
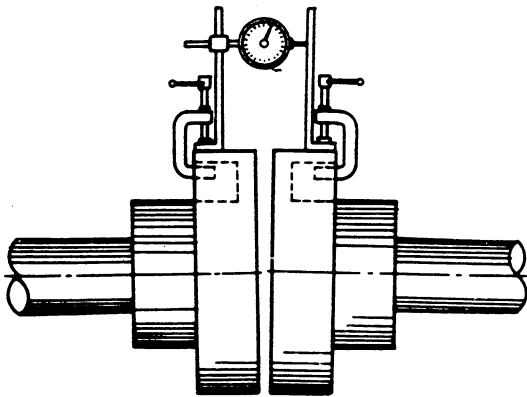

Fig. 3. The preferred method of measuring coupling alignment is with a dial indicator.

- A. Clamp the dial indicator to the coupling as indicated above to measure the circular concentric peripheral surfaces of the coupling halves for parallel alignment.
- B. Clamping a reference surface to the opposite coupling half allows the dial indicator to be used for measuring the separation of the coupling halves for axial alignment as shown below.



BALANCE (DIRECT COUPLED UNITS)

TOSHIBA motors are balanced at the factory to standard NEMA commercial tolerances. However, if direct coupling units have been disassembled in the field, an apparent unbalance may occur if the units are not reassembled with the shafts in the same

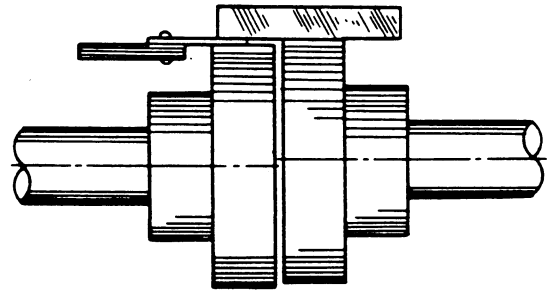
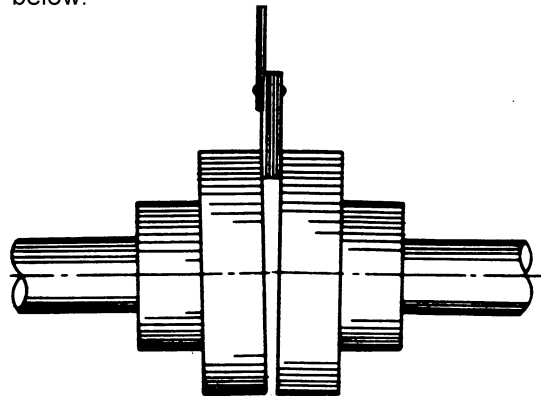

Fig. 4. The straight-edge or thickness gauge or feeler gauge is an alternative method of measuring coupling adjustment.

- A. Use a straight-edge and thickness gauge or feeler gauge to check the alignment of the circular concentric peripheral surfaces of the coupling halves as shown above.
- B. The separation between the faces of the coupling halves can be measured as shown below.



Rigid Coupling tolerances 0.0005 in. to 0.001 in.
Flexible Coupling tolerance: 0.0015 in.

relative position as they were originally. Should this occur, disconnect the coupling halves and rotate one shaft 90° with respect to the other shaft. Re-connect the coupling and run the unit.

If the unbalance has not disappeared, repeat the above procedure until it does.

CONNECTION DIAGRAMS

A. Wye-connected Dual Voltage (low/high voltage) (9 Leads)

POLE	ODP	TEFC & EXP
2P	1 1/2 HP-7 1/2 HP	1 1/2 HP-5HP
4P	1HP-5HP	1HP-5HP
6P	3/4 HP-5HP	3/4 HP-5HP
8P	3/4 HP-5HP	3/4 HP-5HP

A-1 Across the Line Starting

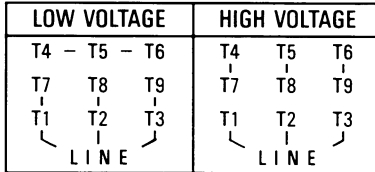

B. Delta-connected Dual Voltage (12 Leads)

POLE	ODP	TEFC & EXP
2 P	10HP-250HP	7 1/2 HP-150HP
4 P	7 1/2 HP-200HP	7 1/2 HP-150HP
6 P	7 1/2 HP-125HP	7 1/2 HP-125HP
8 P	7 1/2 HP-100HP	7 1/2 HP-100HP

B-1 Across the Line Starting

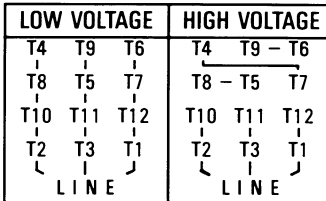

B-2 575 Volt Connection (see Note 1)

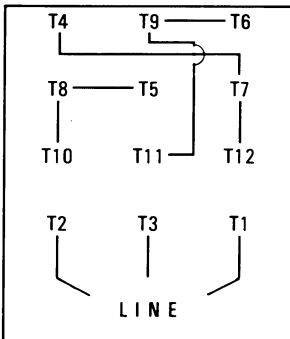

B-3 Wye Start Delta Run

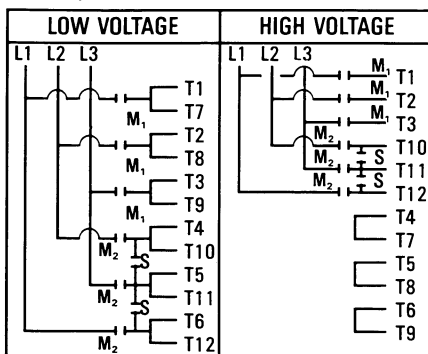

	Start	Run
M ₁	Close	Close
M ₂	Open	Close
S	Close	Open

B-4 Part Winding Starting (see Note 2)

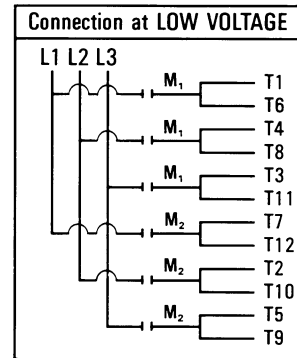

	Start	Run
M ₁	Close	Close
M ₂	Open	Close

M₂ should be energized within 2 seconds after M₁ is energized.

NOTES:

- 230/460 Volt Motors can be used on 575 Volt network in accordance with B-2 connection.
- 4 pole and 6 pole motors are satisfactory for Part Winding starting at low voltage.

C. Delta-connected Single Voltage (6 Leads)

POLE	ODP	TEFC & EXP
2 P	300HP-350HP	200HP-300HP
8 P	125HP-250HP	125HP-250HP

C-1 Across the Line Starting

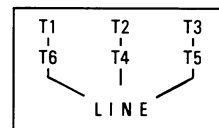

C-2 Wye Start Delta Run

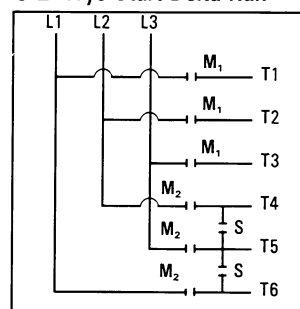

	Start	Run
M ₁	Close	Close
M ₂	Open	Close
S	Close	Open

CONNECTION DIAGRAMS CONT.

D. Delta-connected Single Voltage (12 Leads)

POLE	ODP	TEFC & EXP
2 P	400HP-600HP	—
4 P	250HP-400HP	200HP-400HP
6 P	150HP-300HP	150HP-300HP

D-1 Across the Line Starting

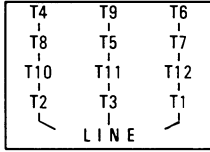

D-2 Wye Start Delta Run

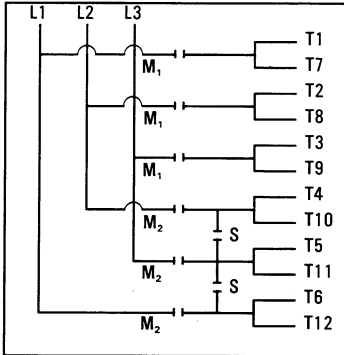

	Start	Run
M ₁	Close	Close
M ₂	Open	Close
S	Close	Open

D-3 Part Winding Starting (4 pole and 6 pole motors)

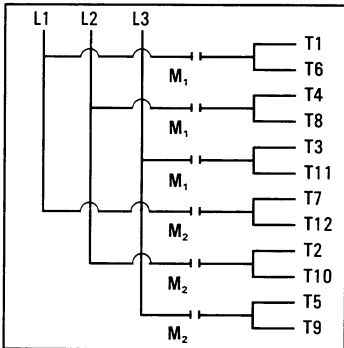

	Start	Run
M ₁	Close	Close
M ₂	Open	Close

M₂ should be energized within 2 seconds after M₁ is energized.

F. Delta-connected 575 Volt Motors (6 Leads)

POLE	ODP	TEFC & EXP
2 P	10HP-500HP	7½HP-300HP
4 P	7½HP-400HP	7½HP-400HP
6 P	7½HP-300HP	7½HP-300HP
8 P	7½HP-250HP	7½HP-250HP

F-1 Across the Line Starting

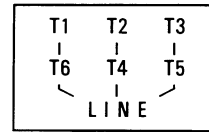

F-2 Wye Start Delta Run

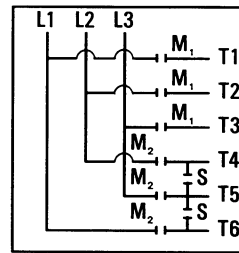

	Start	Run
M ₁	Close	Close
M ₂	Open	Close
S	Close	Open

G. Delta-connected 575 Volt Motors (12 Leads)

POLE	ODP
2 P	600HP

G-1 Across the Line Starting

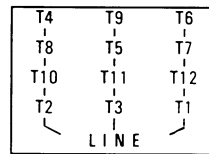

G-2 Wye Start Delta Run

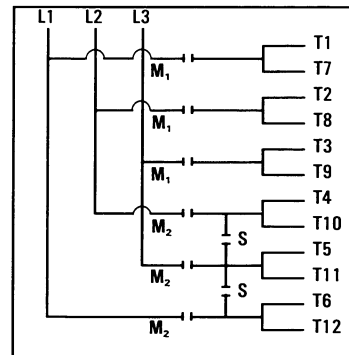

	Start	Run
M ₁	Close	Close
M ₂	Open	Close
S	Close	Open

E. Wye-connected 575 Volt Motors (3 Leads)

POLE	ODP	TEFC & EXP
2 P	1½HP-7½HP	1½HP-5HP
4 P	1HP-5HP	1HP-5HP
6 P	¾HP-5HP	¾HP-5HP
8 P	¾HP-5HP	¾HP-5HP

E-1 Across the Line Starting

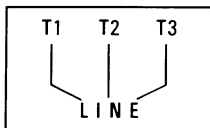

WARNINGS

Motors built F-1 Assembly will be standard counter clockwise rotation facing non drive end of motor. Motors built F-2 Assembly will have clockwise rotation facing non drive end of motor. With the exception of low voltage TEFC 400T through N587UZ Frame motors, whose rotation will remain counter clockwise.

WARNING
BEFORE STARTING MOTOR, REMOVE ALL UNUSED SHAFT KEYS AND LOOSE ROTATING PARTS TO PREVENT THEM FROM FLYING OFF.

CAUTION: Check direction of motor rotation before coupling motor to load.

WARNING
ROTATING PARTS, SUCH AS COUPLINGS, PULLEYS, EXTERNAL FANS, AND UNUSED SHAFT EXTENSIONS, SHOULD BE PERMANENTLY GUARDED AGAINST ACCIDENTAL CONTACT WITH HANDS OR CLOTHING. THIS IS PARTICULARLY IMPORTANT WHERE THE PARTS HAVE SURFACE IRREGULARITIES SUCH AS KEYS, KEYWAYS OR SET SCREWS.

WARNING
WHEN A LIFTING MEANS IS PROVIDED FOR HANDLING THE MOTOR OR GENERATOR, IT SHOULD NOT BE USED TO LIFT THE MOTOR OR GENERATOR PLUS ADDITIONAL EQUIPMENT SUCH AS GEARS, PUMPS, COMPRESSORS, OR OTHER DRIVEN EQUIPMENT.

WARNING
THE FRAMES AND OTHER METAL EXTERIORS OF MOTORS AND GENERATORS (EXCEPT FOR INSULATED PEDESTAL BEARINGS) USUALLY SHOULD BE GROUNDED TO LIMIT THEIR POTENTIAL TO GROUND IN THE EVENT OF ACCIDENTAL CONNECTION OR CONTACT BETWEEN LIVE ELECTRICAL PARTS AND THE METAL EXTERIORS.

WARNING
WHEN CAREFUL CONSIDERATION OF THE HAZARDS INVOLVED IN A PARTICULAR APPLICATION INDICATE THE MACHINE FRAMES SHOULD NOT BE GROUNDED OR WHEN UNUSUAL OPERATING CONDITIONS DICTATE THAT A GROUNDED FRAME CANNOT BE USED, THE INSTALLER SHOULD MAKE SURE THE MACHINE IS PERMANENTLY AND EFFECTIVELY INSULATED FROM GROUND. IN THOSE INSTALLATIONS WHERE THE MACHINE FRAME IS INSULATED FROM GROUND, IT IS RECOMMENDED THAT APPROPRIATE WARNING LABELS OR SIGNS BE PLACED ON OR IN THE AREA OF THE EQUIPMENT BY THE INSTALLER.

WARNING FOR EXPLOSION-PROOF MOTOR

Disconnect power before working on motor driven equipment. This motor is equipped with an automatic temperature-limiting device. The National Electrical Code and Underwriter's Laboratories require connection of leads P1 and P2 into the control circuit of a manual reset starter per following diagram.

KLIXON TYPE	AC VOLT	VOLT AMP RATING
9700K	120-600V	720 VA

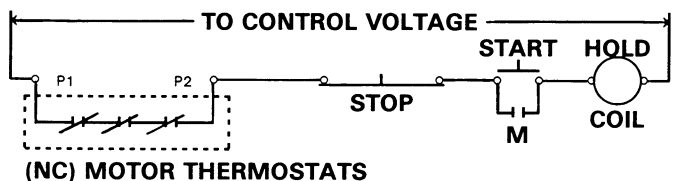

NOTE:
Frame 256T and smaller has two thermostats.

MAINTENANCE

1 INSPECTION

Inspect motor at regular intervals. Keep motor clean and vent openings clear.

2. LUBRICATION

- a) **Frames 143T thru 256T** are furnished with double sealed or shielded ball bearings, prelubricated prior to installation. Grease fittings are not supplied and bearings are designed for average 100,000 hours operation under standard conditions. (See table 2 below.)
- b) **Frames 284T thru N587UZ** are furnished with double shielded or open ball or roller bearings. (Depending on HP size and/or speed.) It is necessary to relubricate anti-friction bearing motors periodically. (See table 2 below.) These motors are supplied with provision for greasing and have been lubricated prior to test, however before start-up it is recommended to apply approximately 30 grams (1 oz.) of grease because of possible settling of grease during storage and handling. However, oil leakage around bearing caps indicate overpacking and excess grease should be purged out by operating motor temporarily with relief open.

Table 2. Frequency of Relubrication

Speed Range	Frame Range	Standard Duty	Severe Duty
2 Pole	143T-256T	*5 Years	* 3 Years
	284TS-286TS	12 Mos.	4 Mos.
	324TS-N587USS	9 Mos.	3 Mos.
4 Pole	143T-256T	*7 Years	* 3 Years
	284T-326T	4 Years	1.5 Years
	364T-365T	2.5 Years	10 Mos.
	404T-447TZ	2 Years	8 Mos.
	505US-N587UZ	1.5 Years	6 Mos.
6 Pole & Slower	143T-256T	*7 Years	3 Years
	284T-326T	4 Years	1.5 Years
	364T-447TZ	3 Years	1 Year
	505US-N587UZ	2 Years	8 Mos.

* The above table shows typical regreasing schedules to be used unless otherwise specified by the motors grease nameplate.

SERVICE CONDITIONS

STANDARD DUTY	Eight hours per day, light to normal loading, clean condition free from dust.
SEVERE DUTY	Twenty-four hours per day, or light to normal shock loading vibration, exposure to dirt or dusty conditions. For very severe conditions where the motor is subject to high vibration or heavy shock loading and vibration use 1/3 of the value shown in the severe duty table.

Remark it is recommended to change bearings after the time shown in Table 2.

3. INSTRUCTIONS FOR LUBRICATING

Toshiba motors (284T-N587UZ) are furnished with grease fittings. Before greasing, be sure fittings are clean and free from dirt. Remove grease relief plug or plate and using a low pressure grease gun, pump in the required grease. Do not overgrease. Relubrication intervals are specified in Table 2 above. After relubricating, allow motor to run for 10 minutes before replacing relief hardware.

4. RECOMMENDED GREASES FOR STANDARD APPLICATIONS

Use the following greases listed for the given temperature range, unless otherwise shown by the motors grease nameplate.

OPERATING AMBIENT TEMP. -30°C to 50°C

CHEVRON SRI	CHEVRON
EXXON UNIREX #2	EXXON CORP.
EXXON POLYREX	EXXON CORP.
SHELL DOLIUM R	SHELL OIL CO

5. RECOMMENDED GREASES FOR SPECIAL APPLICATIONS

The following greases are recommended for special applications only and should be used only for motors specifically built for such conditions.

MIN. AMBIENT TEMP. -60°C BEACON 325 EXXON CORP.

MAX. AMBIENT TEMP. 90°C DOW CORNING 44 DOW CORNING CORP. EXXON LINIREX S2 EXXON CORP.
--

WARNING: In general it is not recommended to mix greases of different brands. The mixing of different types of thickeners may destroy the composition and physical properties of the grease. In the event that a different grease is required by the end user, the following steps can be taken. Using the instructions for lubrication, open grease outlet and purge the system as much as possible of the old or unwanted grease. Repeat this same operation after 1 week of service. Consult TOSHIBA/HOUSTON Engineering for further recommendations on grease compatibility.

WARRANTY

Generally, TOSHIBA will correct at it's option, by repair or replacement (f.o.b. a TOSHIBA-AUTHORIZED SERVICE SHOP), any defect in material and workmanship when properly used for a period of one year after installation or 18 months after shipment, whichever comes first. TOSHIBA is not responsible for apparatus returned without proper authorization and identification, improper handling or storage, misapplication of the motor or the driven equipment, defects in the driven equipment or device, or improper circuit protection. The amount of liability shall not exceed the purchase price of the product. In no event shall TOSHIBA have any liability for commercial loss, claims for labor, removal and installation charges or consequential damages of any type. It is expressly agreed that Buyer's remedies expressed in this paragraph are Buyer's exclusive remedies.

RENEWAL PARTS

1. Use only genuine TOSHIBA renewal parts.
2. When ordering, specify complete information (at least Model Number and Serial Number) of the motor. Specify quantity and describe part.
3. For information and service refer to the nearest TOSHIBA INTERNATIONAL CORPORATION office.

WARNING

EXPLOSION-PROOF MOTORS are constructed to comply with the UL Label Service Procedure Manual. Repairs of EXPLOSION PROOF MOTORS must be made by the manufacturer or U L listed service center to maintain the U L Listing.

FOR FURTHER INFORMATION CONTACT TOSHIBA INTERNATIONAL CORPORATION
 Industrial Equipment Division 13131 W. LITTLE YORK RD., P.O. BOX 40906, HOUSTON, TEXAS 77041