

**TOSHIBA**

**TOSHIBA**  
Leading Innovation >>>



**vlp**  
technology

P9 Adjustable Speed Drive

P9 ASD >>>>  
Quick Start Guide

Document Number: 64055-002

Date: June, 2011



# P9 ASD Quick Start Guide



Document Number: 64055-002

Date: June, 2011



# Introduction

Congratulations on the purchase of the new **P9 Adjustable Speed Drive!**

The **P9 Adjustable Speed Drive (ASD)** is a solid-state AC drive that features Toshiba's new **Virtual Linear Pump** function. Our **VLP** algorithm was designed to remove a lot of the guess work that is inherently associated with the setup of pumping systems. And the **VLP** algorithm allows for precise, linear, and consistent pump curve responses at any flow or pressure setting!

The **Virtual Linear Pump** function allows for direct and precise pumping system control. This is accomplished without the normal concerns of the adverse effects of conventional pumping system control response curves.

The **VLP** algorithm coupled with Toshiba International Corporation's **Vector Control Algorithm** enables the motor to develop high starting torque and provide compensation for motor slip, which results in smooth, quick starts and highly efficient operation.

The P9 ASD uses digitally-controlled pulse width modulation. The programmable functions may be accessed via the easy-to-use menu or via the Direct Access Numbers (see the *P9 ASD Installation and Operation Manual P/N 64054*). This feature, combined with Toshiba International Corporation's high-performance software, delivers unparalleled motor control, reliability, and ease of use.

The P9 ASD is a very powerful tool, yet surprisingly simple to operate. The user-friendly **Electronic Operator Interface (EOI)** of the P9 ASD has an easy-to-read LCD screen. There is also a read-only LED screen with enhanced visibility that can be read from a greater distance. The EOI provides easy access to the many monitoring and programming features of the P9 ASD.

The motor control software is menu-driven, which allows for easy access to the motor control parameters and quick changes when required.

To maximize the abilities of your new P9 ASD, a working familiarity with this guide will be required. This guide has been prepared for the ASD installer, user, and maintenance personnel. This guide may also be used as a reference guide or for training. With this in mind, use this guide to develop a system familiarity before attempting to install or operate the device.

## Important Notice

The instructions contained in this guide are not intended to cover all details or variations in equipment types, nor may it provide contingency concerning the installation, operations, or maintenance of this equipment. Should additional information be required contact your TIC Sales Representative.

The contents of this guide shall not become a part of or modify any prior or existing agreement, commitment, or relationship. The sales contract contains the entire obligation of Toshiba International Corporation. The warranty contained in the contract between the parties is the sole warranty of Toshiba International Corporation and any statements contained herein do not create new warranties or modify the existing warranty.

**Any electrical or mechanical modifications to this equipment without prior written consent of Toshiba International Corporation may void all warranties and may void the UL/CSA listing or other safety certifications. Unauthorized modifications may also result in a safety hazard or equipment damage.**

**Misuse of this equipment could result in injury and equipment damage. In no event will Toshiba International Corporation be responsible or liable for direct, indirect, special, or consequential damage or injury that may result from the misuse of this equipment.**

# About This Guide

This guide was written by the Toshiba International Corporation Technical Publications Group. This group is tasked with providing technical documentation for the **P9 Adjustable Speed Drive**. Every effort has been made to provide accurate and concise information to you, our customer.

At Toshiba International Corporation we are continuously striving for better ways to meet the constantly changing needs of our customers. E-mail your comments, questions, or concerns about this publication to [Technical-Publications-Dept@tic.toshiba.com](mailto:Technical-Publications-Dept@tic.toshiba.com).

## Guide's Purpose and Scope

This guide provides information on how to safely install, operate, maintain, and dispose of your **P9 Adjustable Speed Drive**. The information provided in this guide is applicable to the **P9 Adjustable Speed Drive** only.

This guide provides information on the various features and functions of this powerful cost-saving device, including

- Installation,
- System operation,
- Configuration and menu options, and
- Mechanical and electrical specifications.

Included is a section on general safety instructions that describe the warning labels and symbols that are used throughout the guide. Read the guide completely before installing, operating, performing maintenance, or disposing of this equipment.

This guide and the accompanying drawings should be considered a permanent part of the equipment and should be readily available for reference and review. Dimensions shown in the guide are in metric and/or the English equivalent.

Because of our commitment to continuous improvement, Toshiba International Corporation reserves the right, without prior notice, to update information, make product changes, or to discontinue any product or service identified in this publication.

**Toshiba International Corporation (TIC) shall not be liable for direct, indirect, special, or consequential damages resulting from the use of the information contained within this guide.**

This guide is copyrighted. No part of this guide may be photocopied or reproduced in any form without the prior written consent of Toshiba International Corporation.

© Copyright 2011 Toshiba International Corporation.

**TOSHIBA**® is a registered trademark of Toshiba Corporation. All other product or trade references appearing in this guide are registered trademarks of their respective owners.

All rights reserved.

Printed in the U.S.A.

# Contacting TIC's Customer Support Center

Toshiba International Corporation's Customer Support Center can be contacted to obtain help in resolving any **Adjustable Speed Drive** system problem that you may experience or to provide application information.

The Support Center is open from 8 a.m. to 5 p.m. (CST), Monday through Friday. The Center's toll free number is US (800) 231-1412/Fax (713) 937-9349 CAN (800) 872-2192 MEX 01 (800) 527-1204. For after-hours support follow the directions in the outgoing message when calling.

You may also contact Toshiba International Corporation by writing to:

Toshiba International Corporation

13131 West Little York Road

Houston, Texas 77041-9990

Attn: ASD Product Manager.

For further information on TIC's products and services, please visit our website at [www.toshiba.com/ind/](http://www.toshiba.com/ind/).

## TOSHIBA INTERNATIONAL CORPORATION

### P9 Adjustable Speed Drive

Please complete the Warranty Card supplied with the P9 ASD and return it to Toshiba International Corporation by prepaid mail. This will activate the 12 month warranty from the date of installation; but, shall not exceed 18 months from the shipping date.

Complete the following information and retain for your records.

Model Number: \_\_\_\_\_

Serial Number: \_\_\_\_\_

Project Number (if applicable): \_\_\_\_\_

Date of Installation: \_\_\_\_\_

Inspected By: \_\_\_\_\_

Name of Application: \_\_\_\_\_

# Table of Contents

- General Safety Information ..... 1**
  - Safety Alert Symbol ..... 1
  - Signal Words ..... 1
  - Special Symbols ..... 2
  - Equipment Warning Labels ..... 2
  - Qualified Personnel ..... 2
  - Equipment Inspection ..... 3
  - Handling and Storage ..... 3
  - Disposal ..... 3
- Installation Precautions ..... 4**
  - Location and Ambient Requirements ..... 4
  - Mounting Requirements ..... 4
  - Conductor Routing and Grounding ..... 5
  - Power Connections ..... 6
  - Protection ..... 6
- System Integration Precautions ..... 7**
  - Personnel Protection ..... 7
  - System Setup Requirements ..... 8
- Operational and Maintenance Precautions ..... 9**
- Installation and Connections ..... 10**
  - Installation Notes ..... 10
  - Mounting the ASD ..... 11
  - Connecting the ASD ..... 12
  - Lead Length Specifications ..... 16
  - I/O and Control ..... 17
- Electronic Operator Interface ..... 24**
  - EOI Operation ..... 24
  - Battery Backup ..... 24
  - EOI Remote Mounting ..... 25
  - EOI Features ..... 26
- System Configuration and Menu Options ..... 29**
  - Root Menus ..... 29
- System Operation ..... 59**
  - Operation (Hand) ..... 59
  - Default Setting Changes ..... 60
  - Save User Settings ..... 61
- Virtual Linear Pump ..... 62**

<b>Alarms, Trips, and Troubleshooting .....</b>	<b>66</b>
Alarms and Trips .....	66
User Notification Codes .....	67
Alarms .....	68
Trips/Faults .....	70
<b>Enclosure and Conduit Plate Dimensions .....</b>	<b>76</b>
Enclosure Dimensions .....	76
Conduit Plate Dimensions .....	81
<b>Current/Voltage Specifications .....</b>	<b>84</b>
<b>Cable/Terminal/Torque Specifications .....</b>	<b>86</b>
<b>Short Circuit Protection Recommendations .....</b>	<b>88</b>

# General Safety Information

**DO NOT** attempt to install, operate, maintain, or dispose of this equipment until you have read and understood all of the product safety information and directions that are contained in this manual.

## Safety Alert Symbol

The **Safety Alert Symbol** is comprised of an equilateral triangle enclosing an exclamation mark. This indicates that a potential personal injury hazard exists.



## Signal Words

Listed below are the signal words that are used throughout this manual followed by their descriptions and associated symbols. When the words **DANGER**, **WARNING**, and **CAUTION** are used in this manual, they will be followed by important safety information that must be carefully followed.

The word **DANGER** preceded by the safety alert symbol indicates that an imminently hazardous situation exists that, if not avoided or if instructions are not followed precisely, will result in serious injury to personnel or loss of life.



The word **WARNING** preceded by the safety alert symbol indicates that a potentially hazardous situation exists that, if not avoided or if instructions are not followed precisely, could result in serious injury to personnel or loss of life.



The word **CAUTION** preceded by the safety alert symbol indicates that a potentially hazardous situation exists that, if not avoided or if instructions are not followed precisely, may result in minor or moderate injury.



The word **CAUTION** without the safety alert symbol indicates a potentially hazardous situation exists that, if not avoided or if instructions are not followed precisely, may result in equipment and property damage.

**CAUTION**



# Special Symbols

To identify special hazards, other symbols may appear in conjunction with the **DANGER**, **WARNING**, and **CAUTION** signal words. These symbols indicate areas that require special and/or strict adherence to the procedures to prevent serious injury to personnel or loss of life.

## Electrical Hazard Symbol

A symbol that is comprised of an equilateral triangle enclosing a lightning bolt indicates a hazard of injury from electrical shock or burn.



## Explosion Hazard Symbol

A symbol that is comprised of an equilateral triangle enclosing an explosion indicates a hazard of injury from exploding parts.



# Equipment Warning Labels

**DO NOT** attempt to install, operate, perform maintenance, or dispose of this equipment until you have read and understood all of the product labels and user directions that are contained in this manual.

Warning labels that are attached to the equipment will include the exclamation mark within a triangle. **DO NOT** remove or cover any of these labels. If the labels are damaged or if additional labels are required, contact your TIC Sales Representative.

Labels attached to the equipment are there to provide useful information or to indicate an imminently hazardous situation that may result in serious injury, severe property and equipment damage, or loss of life if safe procedures or methods are not followed as outlined in this manual.

# Qualified Personnel

Installation, operation, and maintenance shall be performed by **Qualified Personnel Only**. A Qualified Person is one that has the skills and knowledge relating to the construction, installation, operation, and maintenance of the electrical equipment and has received safety training on the hazards involved (Refer to the latest edition of NFPA 70E for additional safety requirements).

**Qualified Personnel** shall:

- Have carefully read the entire manual.
- Be familiar with the construction and function of the ASD, the equipment being driven, and the hazards involved.
- Be able to recognize and properly address hazards associated with the application of motor-driven equipment.
- Be trained and authorized to safely energize, de-energize, ground, lock out/tag out circuits and equipment, and clear faults in accordance with established safety practices.
- Be trained in the proper care and use of protective equipment such as safety shoes, rubber gloves, hard hats, safety glasses, face shields, flash clothing, etc., in accordance with established safety practices.

For further information on workplace safety, visit [www.osha.gov](http://www.osha.gov).

# Equipment Inspection

- Upon receipt of the equipment, inspect the packaging and equipment for shipping damage.
- Carefully unpack the equipment and check for parts that may have been damaged during shipping, missing parts, or concealed damage. If any discrepancies are discovered, it should be noted with the carrier prior to accepting the shipment, if possible. File a claim with the carrier if necessary and immediately notify your TIC Sales Representative.
- **DO NOT** install the ASD if it is damaged or if it is missing any component(s).
- Ensure that the rated capacity and the model number specified on the nameplate conform to the order specifications.
- Modification of this equipment is dangerous and is to be performed by factory trained personnel. When modifications are required contact your TIC Sales Representative.
- Inspections may be required after moving equipment.
- Contact your TIC Sales Representative to report discrepancies or for assistance if required.

# Handling and Storage

- Use proper lifting techniques when moving the ASD; including properly sizing up the load, getting assistance, and using a forklift if required.
- Store in a well-ventilated location and preferably in the original packaging if the equipment will not be used upon receipt.
- Store in a cool, clean, and dry location. Avoid storage locations with extreme temperatures, rapid temperature changes, high humidity, moisture, dust, corrosive gases, or metal particles.
- The storage temperature range of the P9 ASD is -13° to 149° F (-25° to 65° C).
- **DO NOT** store the unit in places that are exposed to outside weather conditions (i.e., wind, rain, snow, etc.).
- Store in an upright position.

# Disposal

Never dispose of electrical components via incineration. Contact your state environmental agency for details on disposal of electrical components and packaging in your area.

# Installation Precautions

## Location and Ambient Requirements

- The TIC ASD is intended for permanent installations only.
- Installation should conform to the **National Electrical Code — Article 110** (NEC) (*Requirements For Electrical Installations*), all regulations of the **Occupational Safety and Health Administration**, and any other applicable national, regional, or industry codes and standards.

*Note:* For ALL references to the National Electrical Code (NEC), see the latest release of the National Electrical Code.

- Select a mounting location that is easily accessible, has adequate personnel working space, and adequate illumination for adjustment, inspection, and maintenance of the equipment (refer to the NEC Article 110-13).
- **DO NOT** mount the ASD in a location that would produce catastrophic results if it were to become dislodged from its mounting location (equipment damage or injury).
- **DO NOT** mount the ASD in a location that would allow it to be exposed to flammable chemicals or gases, water, solvents, or other fluids.
- Avoid installation in areas where vibration, heat, humidity, dust, fibers, metal particles, explosive/corrosive mists or gases, or sources of electrical noise are present.
- The installation location shall not be exposed to direct sunlight.
- Allow proper clearance spaces for installation. Do not obstruct the ventilation openings. Refer to the section titled [Installation and Connections on pg. 10](#) for further information on ventilation requirements.
- The ambient operating temperature range of the P9 ASD is 14° to 104° F (-10° to 40° C).

## Mounting Requirements

- Only **Qualified Personnel** should install this equipment.
- Install the unit in a secure and upright position in a well-ventilated area.
- As a minimum, the installation of the equipment should conform to the **NEC — Article 110** (NEC), OSHA, as well as any other applicable national, regional, or industry codes and standards.
- Installation practices should conform to the latest revision of NFPA 70E Electrical Safety Requirements for Employee Workplaces.
- It is the responsibility of the ASD installer/maintenance personnel to ensure that the unit is installed into an enclosure that will protect personnel against electric shock.

# Conductor Routing and Grounding



- Use separate metal conduits for routing the input power, output power, and control circuits.
- A separate ground cable should be run inside the conduit with the input power, output power, and control circuits.
- **DO NOT** connect CC to earth ground.
- Use ICC terminal as the return for the V/I input.
- Always ground the unit to prevent electrical shock and to help reduce electrical noise.
- If the ASD is being used in an ungrounded system (floating system) or in an unsymmetrically grounded system, the EMI filter must be disconnected or removed. The ASD may be damaged if the EMI filter is used.
- It is the responsibility of the ASD installer/maintenance personnel to provide proper grounding and branch circuit protection in accordance with the NEC and any applicable local codes.

— The Metal Conduit Is Not An Acceptable Ground —

## Grounding Capacitor Switch

The ASD is equipped with noise reduction capacitors which are used to reduce the EMI leakage via the 3-phase power-input circuit and for compliance with the **Electromagnetic Compatibility Directive** (EMC).

The effective value of the capacitor may be increased, reduced, or removed entirely via the **Selector Switch**, **Switching Bar**, or the **Switching Screw** — the type used is typeform-specific.

The **Grounding Capacitor Switch** allows the user to quickly change the value of the capacitance of the 3-phase input circuit without the use of tools.

See the section titled [System Grounding on pg. 14](#) for more on the [Grounding Capacitor](#).

See figures [4](#), [5](#), [6](#), and [7 on pg. 15](#) for an electrical depiction of the leakage-reduction functionality of the [Grounding Capacitor](#) and the methods used to set the capacitance value.

# Power Connections



**CONTACT WITH ENERGIZED WIRING WILL CAUSE SEVERE INJURY OR LOSS OF LIFE.**

- Turn off and lock out/tag out all power sources before proceeding to connect the power wiring to the equipment.
- After ensuring that all power sources are turned off and isolated in accordance with established lock out/tag out procedures, connect the 3-phase power source wiring of the correct voltage to the correct input terminals and connect the output terminals to a motor of the correct voltage and type for the application (refer to the NEC Article 300 – Wiring Methods and Article 310 – Conductors For General Wiring). Size the branch circuit conductors in accordance with the NEC Table 310.16.
- Ensure that the 3-phase input power is **NOT** connected to the output of the ASD. This will damage the ASD and may cause injury to personnel.
- **DO NOT** connect resistors across terminals PA – PC or PO – PC. This may cause a fire.
- Ensure the correct phase sequence and the desired direction of motor rotation in the **Bypass** mode (if applicable).

## Protection

- Ensure that primary protection exists for the input wiring to the equipment. This protection must be able to interrupt the available fault current from the power line. The equipment may or may not be equipped with an input disconnect (option).
- All cable entry openings must be sealed to reduce the risk of entry by vermin and to allow for maximum cooling efficiency.
- External dynamic braking resistors must be thermally protected.
- It is the responsibility of the ASD installer/maintenance personnel to set up the **Emergency Off** braking system of the ASD. The function of the **Emergency Off** braking function is to remove output power from the drive in the event of an emergency. A supplemental braking system may also be engaged in the event of an emergency. For further information on braking systems, see parameters **F250** and **F304**.

***Note:** A supplemental emergency stopping system should be used with the ASD. Emergency stopping should not be a task of the ASD alone.*

- Follow all warnings and precautions and do not exceed equipment ratings.

# System Integration Precautions

The following precautions are provided as general guidelines for the setup of the ASD within the system.

- The TIC ASD is a general-purpose product. It is a system component only and the system design should take this into consideration. Please contact your TIC Sales Representative for application-specific information or for training support.
- The TIC ASD is part of a larger system and the safe operation of the ASD will depend upon observing certain precautions and performing proper system integration.
- Improperly designed or improperly installed system interlocks may render the motor unable to start or stop on command.
- The failure of external or ancillary components may cause intermittent system operation (i.e., the system may start the motor without warning).
- A detailed system analysis and job safety analysis should be performed by the systems designer and/or systems integrator before the installation of the ASD component. Contact your TIC Sales Representative for options availability and for application-specific system integration information if required.

## Personnel Protection

- Installation, operation, and maintenance shall be performed by **Qualified Personnel Only**.
- A thorough understanding of the ASD will be required before the installation, operation, or maintenance of the ASD.



- Rotating machinery and live conductors can be hazardous and shall not come into contact with personnel. Personnel should be protected from all rotating machinery and electrical hazards at all times.
- Insulators, machine guards, and electrical safeguards may fail or be defeated by the purposeful or inadvertent actions of workers. Insulators, machine guards, and electrical safeguards are to be inspected (and tested where possible) at installation and periodically after installation for potential hazardous conditions.
- **DO NOT** allow personnel near rotating machinery. Warning signs to this effect shall be posted at or near the machinery.
- **DO NOT** allow personnel near electrical conductors. Contact with electrical conductors can be fatal. Warning signs to this effect shall be posted at or near the hazard.
- Personal Protection Equipment (PPE) shall be provided and used to protect employees from any hazards inherent to system operation.

# System Setup Requirements

- When using the ASD as an integral part of a larger system, it is the responsibility of the ASD installer/maintenance personnel to ensure that there is a fail-safe in place (i.e., an arrangement designed to switch the system to a safe condition if there is a fault or failure).
- Power factor improvement capacitors or surge absorbers **MUST NOT** be installed on the output of the ASD.
- Use of the built-in system protective features is highly recommended (i.e., E-Off, Overload Protection, etc.).
- The operating controls and system status indicators should be clearly readable and positioned where the operator can see them without obstruction.
- Additional warnings and notifications shall be posted at the equipment installation location as deemed required by [Qualified Personnel](#).



## CAUTION

- System safety features should be employed and designed into the integrated system in a manner such that system operation, even in the event of system failure, will not cause harm or result in system damage or injury to personnel (i.e., E-Off, Auto-Restart settings, System Interlocks, etc.).
- The programming setup and system configuration of the ASD may allow it to start the motor unexpectedly. A familiarity with the **Auto-Restart** (F301), **Sleep Timer** (F383), and the **Start-Stop** (F385) settings are a requirement to use this product.
- There may be thermal or physical properties, or ancillary devices integrated into the overall system that may allow for the ASD to start the motor without warning. Signs to this effect must be posted at the equipment installation location.
- If a secondary magnetic contactor (MC) or an ASD output disconnect is used between the ASD and the load, it should be interlocked to halt the ASD before the secondary contact opens. If the output contactor is used for bypass operation, it must be interlocked such that commercial power is never applied to the ASD output terminals (U, V, or W).
- When using an ASD output disconnect, the ASD and the motor must be stopped before the disconnect is either opened or closed. Closing the output disconnect while the 3-phase output of the ASD is active may result in equipment damage or injury to personnel.

# Operational and Maintenance Precautions



- Turn off and lock out/tag out the main power, the control power, and instrumentation connections before inspecting or servicing the drive, opening the door of the enclosure, or connecting/disconnecting the power wiring to the equipment.
- The capacitors of the ASD maintain a residual charge for a period of time after turning the ASD off. The required time for each ASD typeform is indicated with a cabinet label and a **Charge LED** (shown for smaller ASDs in [Figure 2 on pg. 12](#); LED is located on the front panel of larger ASDs). Wait at least the minimum time indicated on the enclosure-mounted label and ensure that the **Charge LED** has gone out before opening the door of the ASD once the ASD power has been turned off.
- Turn the power on only after attaching (or closing) the front cover and **DO NOT** remove or open the front cover of the ASD when the power is on.
- **DO NOT** attempt to disassemble, modify, or repair the ASD. Call your TIC Sales Representative for repair information.
- **DO NOT** place any objects inside of the ASD.
- If the ASD should emit smoke, or an unusual odor or sound, turn off the power immediately.
- The heat sink and other components may become extremely hot to the touch. Allow the unit to cool before coming in contact with these items.
- The **Auto Start-Stop** programmable functions and the **Sleep Timer** function of the ASD may allow for the system to start or stop unexpectedly. Signs to this effect are to be clearly posted at the installation location.
- Remove power from the ASD during extended periods of non-use.
- The system should be inspected periodically for damaged or improperly functioning parts, cleanliness, and to ensure that the connectors are tightened securely.



# Installation and Connections

The **P9 True Torque Control<sup>2</sup> Adjustable Speed Drive** may be set up initially by performing a few simple configuration settings. To operate properly, the ASD must be securely mounted and connected to a power source (3-phase AC input at the R/L1, S/L2, and T/L3 terminals). The control terminals of the ASD may be used by connecting the terminals of the **Terminal Board** to the proper sensors or signal input sources (see the section titled [I/O and Control on pg. 17](#) and [Figure 9 on pg 20](#)).

System performance may be further enhanced by assigning a function to the output terminals of the **Terminal Board** and connecting the terminals to the proper indicators or actuators (e.g., LEDs, relays, contactors, etc.).

*Note:* The optional ASD interface boards may be used to expand the I/O functionality of the ASD.

## Installation Notes

### CAUTION

When a brake-equipped motor is connected to the ASD, it is possible that the brake may not release at startup because of insufficient voltage. To avoid this, **DO NOT** connect the brake or the brake contactor to the output of the ASD.

If an output contactor is used for bypass operation, it must be interlocked such that commercial power is never applied to the output terminals of the ASD (U/T1, V/T2, and W/T3).

**DO NOT** apply commercial power to the ASD output terminals **U/T1**, **V/T2**, and **W/T3**.

If a secondary magnetic contactor (MC) is used between the output of the ASD and the motor, it should be interlocked such that the **ST – CC** connection is disconnected before the output contactor is opened.

**DO NOT** open and then close a secondary magnetic contactor between the ASD and the motor unless the ASD is off and the motor is not rotating.

*Note:* Re-application of power via a secondary contact while the ASD is on or while the motor is still turning may cause ASD damage.

The ASD input voltage should remain within 10% of the specified input voltage range. Input voltages approaching the upper or lower-limit settings may require that the over-voltage and under-voltage stall protection level parameters be adjusted. Voltages outside of the permissible tolerance should be avoided.

The frequency of the input power should be  $\pm 2$  Hz of the specified input frequency.

**DO NOT** use an ASD with a motor that has a current rating that is greater than the rated current of the ASD.

The P9 ASD is designed to operate NEMA B motors. Consult with your TIC Sales Representative before using the ASD for special applications such as with an explosion-proof motor or applications with a piston load.

Disconnect the ASD from the motor before megging or applying a bypass voltage to the motor.

Interface problems may occur when an ASD is used in conjunction with some types of process controllers. Signal isolation may be required to prevent controller and/or ASD malfunction (contact your TIC Sales Representative or the process controller manufacturer for additional information on compatibility and signal isolation).

Use caution when setting the output frequency. Over speeding a motor decreases its ability to deliver torque and may result in damage to the motor and/or the driven equipment.

Not all P9 ASDs are equipped with internal primary power input fuses (HP dependent). When connecting two or more drives that have no internal fuse to the same power line as shown in [Figure 1](#), select a circuit-breaking configuration that will ensure that if a short circuit occurs in ASD 1, only MCCB2 trips, not MCCB1. If it is not feasible to use this configuration, insert a fuse between MCCB2 and ASD 1.

Figure 1. Typical Circuit Breaker Configuration.

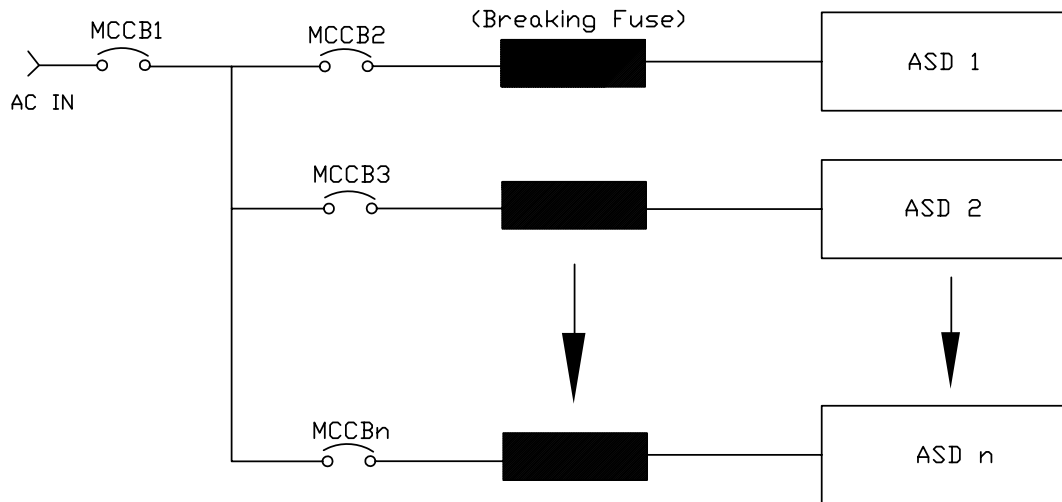

## Mounting the ASD

### CAUTION

— The following thermal specifications apply to the 230-volt and 460-volt ASDs ONLY —

Install the unit securely in a well ventilated area that is out of direct sunlight.

The process of converting AC to DC, and then back to AC produces heat. During normal ASD operation, up to 5% of the input energy to the ASD may be dissipated as heat. If installing the ASD in a cabinet, ensure that there is adequate ventilation.

**DO NOT** operate the ASD with the enclosure door open.

The ambient operating temperature rating of the P9 ASD is 14° to 104° F (-10° to 40° C).

When installing adjacent ASDs horizontally, TIC recommends at least 5 cm of space between adjacent units. However, horizontally mounted ASDs may be installed side-by-side with no space in between the adjacent units — side-by-side installations require that the top cover be removed from each ASD.

For 150 HP and above ASDs, a minimum of 50 cm of space is required above and below adjacent units and any obstruction. This space is the recommended minimum space requirement for the ASD and ensures that adequate ventilation is provided for each unit. More space will provide a better environment for cooling (see the section titled [Enclosure and Conduit Plate Dimensions](#) on [pg. 76](#) for additional information on mounting space requirements).

*Note:* Ensure that the ventilation openings are not obstructed.

# Connecting the ASD



Refer to the section titled [Installation Precautions on pg. 4](#) and the section titled [Lead Length Specifications on pg. 16](#) before attempting to connect the ASD and the motor to electrical power.

## Power Connections



**Contact With 3-Phase Input/Output Terminals May Cause An Electrical Shock Resulting In Injury Or Loss Of Life.**

See the [Typical Connection Diagram on pg. 22](#) for a system I/O connectivity schematic.

An inductor (DCL) may be connected across the **PO** and **PA/+** terminals to provide additional filtering. When not used, a jumper must be connected across these terminals.

**PA/+** and **PB** are used for the DBR connection if using a braking resistor.

**PC/-** is the negative terminal of the DC bus.

**R/L1**, **S/L2**, and **T/L3** are the 3-phase input supply terminals for the ASD.

**U/T1**, **V/T2**, and **W/T3** are the output terminals of the ASD that connect to the motor.

The location of the **Charge LED** for the smaller typeform ASD is provided in [Figure 2](#). The **Charge LED** is located on the front door of the enclosure of the larger ASDs.

Figure 2. Typical P9 ASD Input/Output Terminals and the [Grounding Capacitor Switch](#).

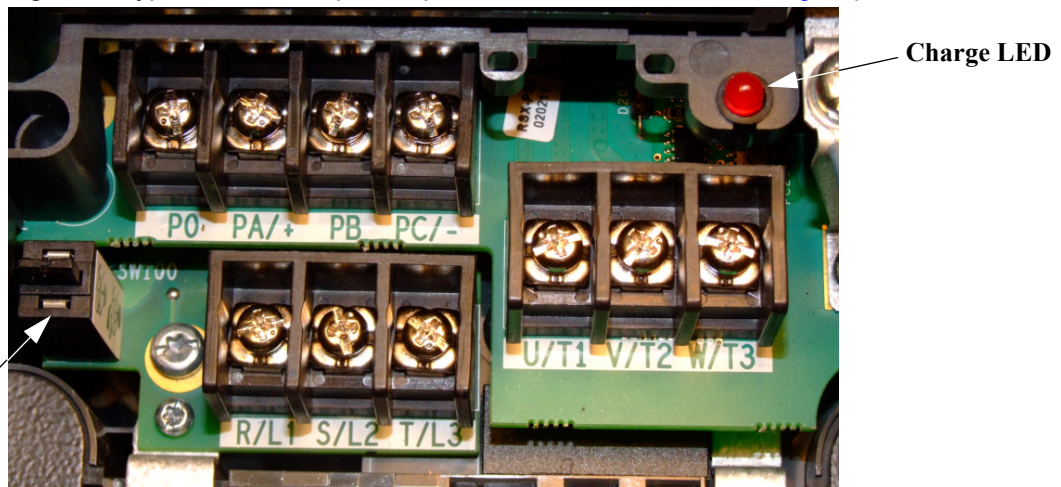

**Grounding Capacitor Switch** — Pull for **Small** capacitance/push for **Large** capacitance.

# Power Connection Requirements

Connect the 3-phase input power to the input terminals of the ASD at **R/L1**, **S/L2**, and **T/L3** (see [Figure 3](#) for the typical electrical connection scheme). Connect the output of the ASD to the motor from the ASD terminals **U/T1**, **V/T2**, and **W/T3**. The input and output conductors and terminal lugs used shall be in accordance with the requirements listed in the section titled [Current/Voltage Specifications on pg. 84](#).

If multiple conductors are used in parallel for the input or output power and it is necessary to use separate conduits, each parallel set shall have its own conduit and not share its conduit with other parallel sets (i.e., place U1, V1, W1, and a ground wire in one conduit and U2, V2, W2 and a ground wire in another; refer to the NEC Article 300.20 and Article 310.4). National and local electrical codes should be referenced if three or more power conductors are run in the same conduit (refer to the NEC Article 310 adjustment factors).

**Note:** *National and local codes should be referenced when running more than three conductors in the same conduit.*

Install a molded case circuit breaker (MCCB) or fuse between the 3-phase power source and the ASD in accordance with the fault current setting of the ASD and the **NEC Article 430**.

The ASD is designed and tested to comply with UL Standard 508C. Modifications to the ASD system or failure to comply with the short circuit protection requirements outlined in this manual may disqualify the UL rating. See [Table 13 on pg. 88](#) for typeform-specific short circuit protection recommendations.

As a minimum, the installation of the ASD shall conform to the **NEC Article 110**, the **Occupational Safety and Health Administration** requirements, and to any other local and regional industry codes and standards.

**Note:** *In the event that the motor rotates in the wrong direction when powered up, reverse any two of the three ASD output power leads (U, V, or W) connected to the motor.*

Figure 3. P9 ASD/Motor Typical Connection Diagram.

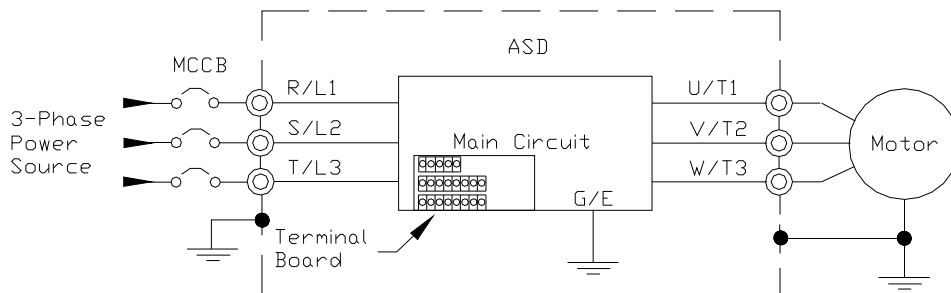

# System Grounding

Proper grounding helps to prevent electrical shock and to reduce electrical noise. The ASD is designed to be grounded in accordance with **Article 250** of the **NEC** or **Section 10/Part One** of the **Canadian Electrical Code (CEC)**.

The grounding conductor shall be sized in accordance with **Article 250-122** of the **NEC** or **Part One-Table 6** of the **CEC**.

## — The Metal Conduit Is Not An Acceptable Ground —

The input, output, and control lines of the system shall be run in separate metal conduits and each shall have its own ground conductor.

ASDs produce high-frequency noise — take steps to avoid the negative effects of noise. Listed below are some examples of measures that will help to combat noise problems.

- **DO NOT** install the input power and output power wires in the same duct or in parallel with each other, and do not bind them together.
- **DO NOT** install the input/output power wires and the wires of the control circuit in the same duct or in parallel with each other, and do not bind them together.
- Use shielded wires or twisted wires for the control circuits.
- Ensure that the grounding terminals (G/E) of the ASD are securely connected to ground.
- Connect a surge suppressor to every electromagnetic contactor and every relay installed near the ASD.
- Install noise filters as required.

## Grounding Capacitor

The **Grounding Capacitor** plays a role in minimizing the effects of leakage current through the ASD system and through ground paths to other systems. Leakage current may cause the improper operation of earth-leakage current breakers, leakage-current relays, ground relays, fire alarms, and other sensors — and it may cause superimposed noise on CRT screens.

The **Grounding Capacitor Switch** allows the user to quickly change the value of the leakage-reduction capacitance of the 3-phase input circuit. See figures 4, 5, 6, and 7 on pg. 15 for an electrical depiction of the leakage-reduction functionality and the methods used to change the capacitance value. The method used is typeform-specific.

If using a 460-volt 5 HP ASD or a 460-volt ASD that is in the range of 7.5 HP to 25 HP, and the **U/T1**, **V/T2**, and **W/T3** connections to the motor are 100 meters or more in length, the ASD **Carrier Frequency** must be set to 4 kHz or less when activating or deactivating the **Grounding Capacitor Switch**. ASD overheating may occur if the **Carrier Frequency** is set above 4 kHz when activating or deactivating the **Grounding Capacitor Switch**.

See pg. 5 for more information on the **Grounding Capacitor Switch** and pg. 12 for the location.

Figure 4. The **Grounding Capacitor**

**Switch** is used on typeforms **230-volt** 0.75 HP to 10 HP and the 25 and 30 HP/**460-volt** 1.0 HP to 25 HP.

The value may be set to **Maximum** (default setting) or to **Zero** by pushing or pulling the switch actuator, respectively.

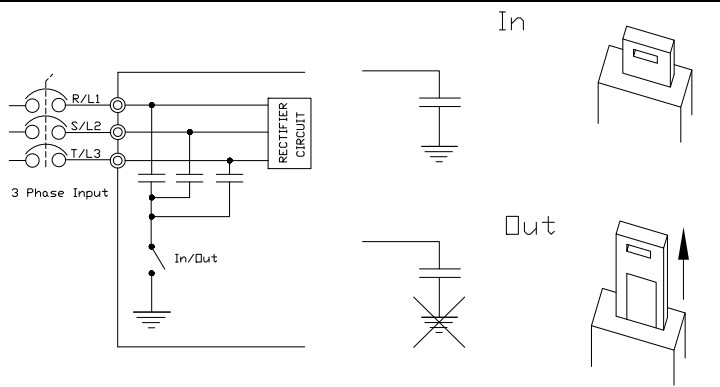

Figure 5. The **Grounding Capacitor**

**Switch** is used on typeforms **230-volt** 15 HP and 20 HP and the 40 HP to 60 HP/**460-volt** 30 HP to 100 HP.

The value may be set to **Large** (default setting) or **Small** by pushing or pulling the switch actuator, respectively.

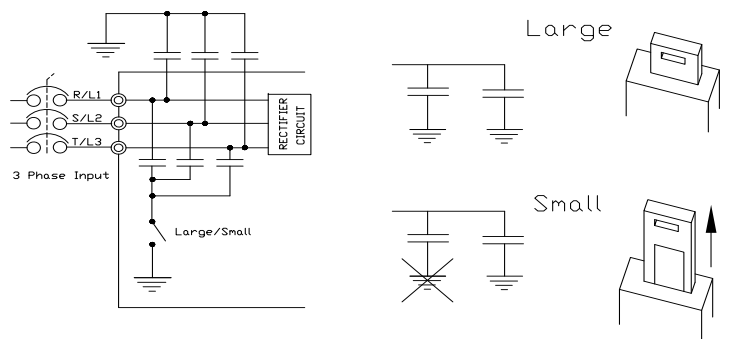

Figure 6. The **Grounding Capacitor**

**Bar** is used on typeforms **230-volt** 75 HP to 125 HP/**460-volt** 125 HP and the 150 HP.

The value may be set to **Large** or **Small** (default setting) by connecting or disconnecting the switching bar, respectively.

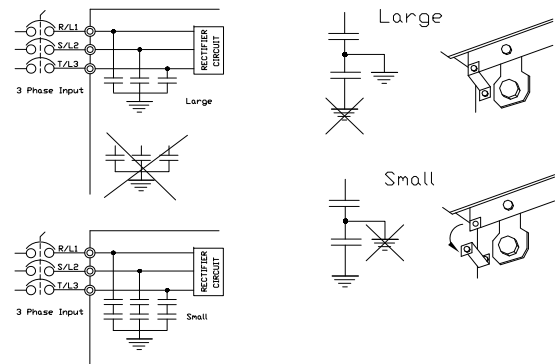
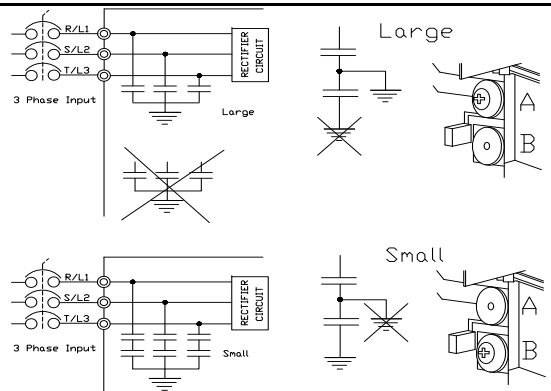

Figure 7. The **Grounding Capacitor**

**Screw** is used on typeforms **460-volt** 200 HP and above.

The value may be set to **Large** or **Small** (default setting) by placing the screw in the **A** position or by placing the screw in the **B** position, respectively.



# Lead Length Specifications

Adhere to the NEC and any local codes during the installation of ASD/motor systems. Excessive lead lengths may adversely affect the performance of the motor. Special cables are not required.

Lead lengths from the ASD to the motor in excess of those listed in [Table 1](#) may require filters to be added to the output of the ASD.

All Toshiba CT motors use an insulation system that is NEMA MG1 Part 30 compliant.

All Toshiba XT motors use an insulation system that is NEMA MG1 Part 31 compliant.

[Table 1](#) lists the suggested maximum lead lengths for the listed motor voltages..

Table 1. Lead Length Recommendations.

Model	PWM Carrier Frequency	NEMA MG1 Part 30 Compliant Motors	NEMA MG1 Part 31 Compliant Motors
230-Volt	All	450 feet	1000 feet
460-Volt	≤ 5 kHz	200 feet	600 feet
	> 5 kHz	100 feet	300 feet

**Note:** *Contact the TIC Customer Support Center for application assistance when using lead lengths in excess of those listed or for filter selection assistance for a given application.*

*Exceeding the peak voltage rating or the allowable thermal rise time of the motor insulation will reduce the life expectancy of the motor.*

*When operating in the **Vector Control** mode, the carrier frequency should be set to 2.2 kHz or above.*

# I/O and Control

The ASD can be controlled by several input types and combinations thereof, as well as operate within a wide range of output frequency and voltage levels. This section discusses the ASD control methods and supported I/O functions.

The **Terminal Board** supports discrete and analog I/O functions and is shown in [Figure 9 on pg 20](#). [Table 2](#) lists the names, functions, and settings (default settings of programmable terminals) of the input and output terminals of the **Terminal Board**.

**Note:** To use the input lines of the **Terminal Board** to provide **Run** commands, the **Command Mode** setting must be set to **Terminal Block**.

[Typical Connection Diagram on pg. 22](#) shows the typical connection diagram for the ASD system.

Table 2. Terminal Board Terminal Names and Functions.

Terminal Name	Input/Output	Function (Default Setting If Programmable) (See <a href="#">Terminal Descriptions on pg. 18</a> )	Circuit Config.
ST	Discrete Input  Connect to CC to activate (Sink mode).	<b>Standby</b> — Multifunctional programmable discrete input. Activation required for normal ASD operation.	<a href="#">Figure 10 on pg 21</a> .
RES		<b>Reset</b> — Multifunctional programmable discrete input. Resets a faulted ASD.	
F		<b>Forward</b> — Multifunctional programmable discrete input.	
R		<b>Reverse</b> — Multifunctional programmable discrete input.	
S1		<b>Preset Speed 1</b> — Multifunctional programmable discrete input.	
S2		<b>Preset Speed 2</b> — Multifunctional programmable discrete input.	
S3		<b>Preset Speed 3</b> — Multifunctional programmable discrete input.	
S4		<b>Preset Speed 4</b> — Multifunctional programmable discrete input.	
O1A/B (OUT1)	Switched Output	<b>External Device 1</b> — Multifunctional programmable discrete output.	<a href="#">Figure 16 on pg 21</a> .
O2A/B (OUT2)		<b>External Device 2</b> — Multifunctional programmable discrete output.	
FLA		Fault relay (N.O.).	<a href="#">Figure 19 on pg 21</a> .
FLB		Fault relay (N.C.).	
FLC		Fault relay (common).	
RR	Analog Input	<b>Frequency Mode 1</b> — Multifunction programmable analog input. (0.0 to 10 VDC input — 0 Hz to Maximum Frequency).	<a href="#">Figure 11 on pg 21</a> .
RX		Multifunctional programmable analog input (-10 to +10 VDC input).	<a href="#">Figure 12 on pg 21</a> .
V/I (Select V or I via SW301)		Unassigned — <b>V</b> — Multifunctional programmable isolated analog voltage input (0 to 10 VDC input).	<a href="#">Figure 13 on pg 21</a> .
		<b>Frequency Mode 2</b> (default SW301 setting) — <b>I</b> — Multifunctional programmable isolated analog current input (4 [0] to 20 mADC input — 0 Hz to Maximum Frequency).	
AM	Analog Output	<b>Output Current</b> — Current output that is proportional to the output current of the ASD or to the magnitude of the function assigned to this terminal.	<a href="#">Figure 18 on pg 21</a>
FM		<b>Output Frequency</b> — <u>Current</u> or <u>Voltage</u> output that is proportional to the output frequency of the ASD or to the magnitude of the function assigned to this terminal. Select <b>Current</b> or <b>Voltage</b> at <b>F681</b> .	
SU+	DC Input	Externally-supplied 24 VDC backup control power (1.1 A min.).	
P24	DC Output	24 VDC output (200 mA max.).	<a href="#">Figure 14 on pg 21</a> .
PP		10.0 VDC/10 mA voltage source for an external potentiometer.	<a href="#">Figure 15 on pg 21</a> .
FP	Pulsed Output	<b>Frequency Pulse</b> — Multifunctional programmable output pulse train of a frequency based on the output frequency of the ASD.	<a href="#">Figure 17 on pg 21</a> .
IICC	—	Return for the V/I input terminal.	<b>DO NOT</b> connect to <b>Earth Gnd</b> or to each other.
CCA	—	Return for the RR, RX, P24, and the PP terminals.	
CC	—	Return for the AM, FM, SU+, and the discrete input terminals.	



# Terminal Descriptions

**Note:** The programmable terminal assignments may be accessed and changed from the default settings as mapped on [pg. 34](#) or via the **Direct Access** method: *Program* ⇒ *Direct Access* ⇒ **Applicable Parameter Number**. See the section titled [Program Mode Menu Navigation on pg. 34](#) for the applicable **Direct Access** parameter numbers. For further information on terminal assignments and default setting changes, see the sections titled [Terminal on pg. 36](#) and [Default Setting Changes on pg. 60](#).

**Note:** See the section titled [Cable/Terminal/Torque Specifications on pg. 86](#) for the ASD conductor and terminal electrical specifications.

**ST** — The default setting for this terminal is the **Standby** mode controller. As the default setting, this terminal must be activated for normal system operation. The **ST** terminal is activated by connecting **CC** to this terminal (Sink mode). When deactivated, **OFF** is flashed on the LED screen and the **Not-Ready-to-Run** icon is displayed on the LCD screen as shown in [Figure 22 on pg 28](#). This input terminal may be programmed to any of the functions listed in the *P9 ASD Installation and Operation Manual* (see F113).

**RES** — The default setting for this terminal is **Reset**. The **RES** terminal is activated by connecting **CC** to this terminal (Sink mode). A momentary connection to **CC** resets the ASD and any fault indications from the display. **Reset** is effective when faulted only. This input terminal may be programmed to any of the functions listed in the *P9 ASD Installation and Operation Manual* (see F114).

**F** — The default setting for this terminal is the **Forward** run command. The **F** terminal is activated by connecting **CC** to this terminal (Sink mode). This input terminal may be programmed to any of the functions listed in the *P9 ASD Installation and Operation Manual* (see F111).

**R** — The default setting for this terminal is the **Reverse** run command. The **R** terminal is activated by connecting **CC** to this terminal (Sink mode). This input terminal may be programmed to any of the functions listed in the *P9 ASD Installation and Operation Manual* (see F112).

**S1** — The default setting for this terminal is the **Preset Speed 1**. The **S1** terminal is activated by connecting **CC** to this terminal (Sink mode). This input terminal may be programmed to any of the functions listed in the *P9 ASD Installation and Operation Manual* (see F115).

**S2** — The default setting for this terminal is the **Preset Speed 2**. The **S2** terminal is activated by connecting **CC** to this terminal (Sink mode). This input terminal may be programmed to any of the functions listed in the *P9 ASD Installation and Operation Manual* (see F116).

**S3** — The default setting for this terminal is the **Preset Speed 3**. The **S3** terminal is activated by connecting **CC** to this terminal (Sink mode). This input terminal may be programmed to any of the functions listed in the *P9 ASD Installation and Operation Manual* (see F117).

**S4** — The default setting for this terminal is the **Preset Speed 4**. The **S4** terminal is activated by connecting **CC** to this terminal (Sink mode). This input terminal may be programmed to any of the functions listed in the *P9 ASD Installation and Operation Manual* (see F118).

**RR** — The default function assigned to this terminal is **Frequency Mode 1**. The **RR** terminal accepts a 0 – 10 VDC input signal that is used to control the function assigned to this terminal. This input terminal may be programmed to control the speed or torque of the motor via an amplitude setting or regulate by setting a limit. The gain and bias of this terminal may be adjusted for application-specific suitability (see F210 – F215).

**RX** — The default function assigned to this terminal is **Torque Command**. The **RX** terminal accepts a ±10 VDC input signal that is used to control the function assigned to this terminal. This input terminal may be programmed to raise or lower the speed or torque of the motor via an amplitude setting or this

terminal may be used to regulate the speed or torque of a motor by setting a limit. The gain and bias of this terminal may be adjusted for application-specific suitability (see F216 – F221).

**V/I** — The V/I terminal has the dual function of being able to receive an input voltage or current. The function as a voltage input is to receive a 0 – 10 VDC input signal. The function as a current input is to receive a 0 – 20 mA input signal. Using either input type, the function is to control the 0.0 – Maximum Frequency output or the 0.0 to 250% torque output of the ASD. This is an isolated input terminal. This terminal may be programmed to control the speed or torque of the motor and cannot process both input types simultaneously. **SW301** must be set to V or I to receive a voltage or current, respectively (see [Figure 9 on pg 20](#)). Terminal scaling is accomplished via F201 – F206. The gain and bias of this terminal may be adjusted for application-specific suitability (see F470 – F471).

**SU+** — **Control Power Supply Backup** input terminal. This terminal accepts the user-supplied 24 VDC backup power to the control circuits (only). Backup power is used in the event of an open MCCB or during a momentary loss of the 3-phase input power. Parameter settings, real-time clock information, and trip history information are retained with the use of the **SU+** backup power. See the section titled [Battery Backup on pg. 24](#) for more information on system backup features.

**P24** — +24 VDC at 200 mA power supply for customer use.

**PP** — The function of output **PP** is to provide a 10 VDC/10 mADC (max.) output that may be divided using a potentiometer. The tapped voltage is applied to the **RR** input to provide manual control of the **RR** programmed function.

**01A/B** (OUT1A/B) — The default function assigned to this terminal is **External Device 1**. The function as **External Device 1** is to activate/deactivate an auxiliary motor once the VLP level has remained within the **VLP Maximum Zone** or the **VLP Minimum Zone** for the time setting of **F480**. The **OUT1** terminal is rated at 2 A/120 VAC and 2 A/30 VDC. This terminal may be set to any of the functions listed in the ***P9 ASD Installation and Operation Manual*** (see F130).

**02A/B** (OUT2A/B) — The default function assigned to this terminal is **External Device 2**. The function as **External Device 2**, in conjunction with External Device 1, is to activate/deactivate an auxiliary motor once the VLP level has remained within the **VLP Maximum Zone** or the **VLP Minimum Zone** for the time setting of **F480**. The **OUT2** terminal is rated at 2 A/120 VAC and 2 A/30 VDC. This terminal may be set to any of the functions listed in the ***P9 ASD Installation and Operation Manual*** (see F131).

**FP** — The default function of this output terminal is to output a series of pulses at a rate that is a function of the ASD output frequency (50 mA max. at 1.0 kHz to 43.3 kHz). As the output frequency of the ASD goes up so does the **FP** output pulse rate. This terminal may be programmed to provide an output pulse rate that is proportional to the magnitude of the user-selected item from the ***P9 ASD Installation and Operation Manual***. For further information on this terminal, see parameter **F676**.

**AM** — This output terminal produces an output current that is proportional to the output frequency of the ASD or of the magnitude of the function assigned to this terminal. The available assignments for this output terminal are listed in the ***P9 ASD Installation and Operation Manual***. For further information on this terminal, see **F670**.

**FM** — This output terminal produces an output current or voltage that is proportional to the output frequency of the ASD or of the magnitude of the function assigned to this terminal. The available assignments for this output terminal are listed in the ***P9 ASD Installation and Operation Manual***. For further information on this terminal, see **F005**. The Voltage/Current output selection is performed at **F681**.

**FLA** — One of two normally open contacts that, under user-defined conditions, connect to **FLC**.

**FLB** — One of two normally closed contacts that, under user-defined conditions, connect to **FLC**.

**FLC** — **FLC** is the common leg of a single-pole double-throw form C relay. The **FL** relay is the **Fault Relay** by default, but may be programmed to any of the selections listed in the ***P9 ASD Installation and Operation Manual***. For further information on this terminal, see **F132** and [Figure 8 on pg 20](#).

**Note:** The *FLA*, *FLB*, and *FLC* contacts are rated at 2A/120 VAC and 2A/30 VDC.

Figure 8. FLA, FLB, and FLC Switching Contacts Shown in the Normal Operating Condition.

**Note:** The relay is shown in the normal operating condition. During a **faulted** condition, the relay connection is **FLC-to-FLA**.

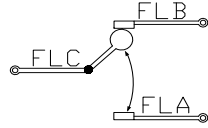
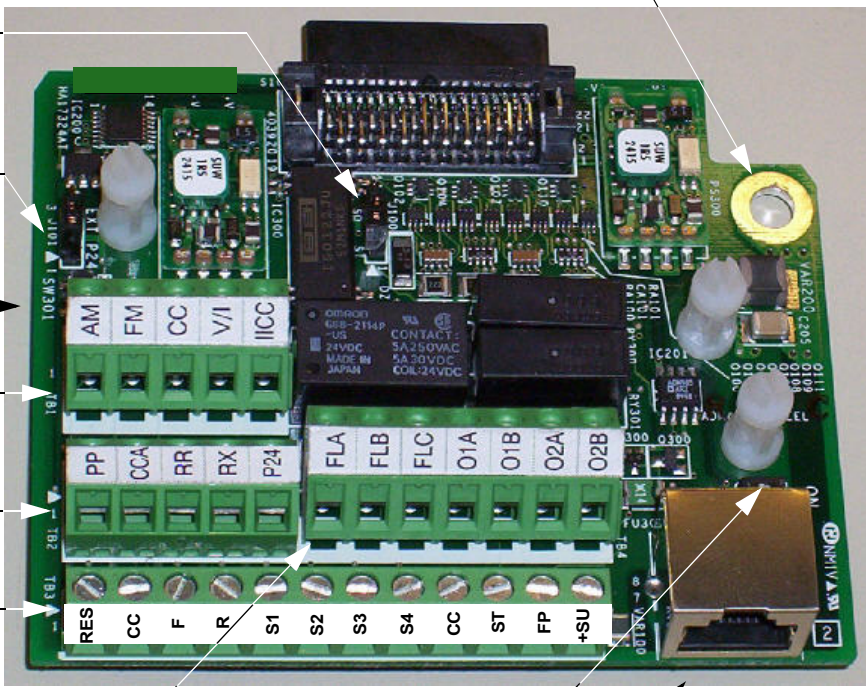

Figure 9. Terminal Board.

**CAUTION** Ensure that the ground screw is securely in place to prevent arcing, intermittent operation, or system failure.



**J100**  
1 to 2 = Sink (\*)  
2 to 3 = Source

**J101 (24V)**  
1 to 2 = Sys. Supplied (\*)  
2 to 3 = Ext. Supplied

**SW301**  
V/I Switch (\*)

**TB1**

**TB2**

**TB3**

**TB4**

**SW200**  
Half / Full Duplex (\*) Switch

**S4**  
RS485 4-Wire Communication

\* = Default Setting

See [Typical Connection Diagram on pg. 22](#) for more information on the Terminal Board.

See the section titled [Terminal Descriptions on pg. 18](#) for terminal descriptions.

See the section titled [Cable/Terminal/Torque Specifications on pg. 86](#) for information on the proper cable/terminal sizes and torque specifications when making **Terminal Board** connections.

# I/O Circuit Configurations

<p><b>Figure 10. Discrete Input.</b></p> <p>Input CC or 24 VDC 5 mA MAX.</p> <p>To Control Board</p> <p>P24 Sink Source</p>	<p><b>Figure 11. RR Input.</b></p> <p>30kΩ Input Impedance</p> <p>15kΩ</p> <p>15kΩ</p> <p>0.047 μf</p> <p>CCA</p> <p>P5</p> <p>Use the CCA terminal as the RR signal return.</p>
<p><b>Figure 12. RX Input.</b></p> <p>30kΩ Input Impedance</p> <p>15kΩ</p> <p>7kΩ</p> <p>CCA</p> <p>P15</p> <p>Use the CCA terminal as the RX signal return.</p>	<p><b>Figure 13. V/I Isolated Input.</b></p> <p>256.7Ω Input Impedance</p> <p>I (Current)</p> <p>V (Voltage)</p> <p>SW301 Setting</p> <p>29.7 kΩ Input Impedance</p> <p>P15C</p> <p>P15A</p> <p>N15C</p> <p>N15A</p> <p>To Cont. Board</p> <p>IICC</p> <p>Use the IICC terminal as the V/I signal return.</p>
<p><b>Figure 14. P24 Output.</b></p> <p>Output</p> <p>24 VDC 200 mA Max.</p> <p>CC</p> <p>0.047 μF</p> <p>J101 1 (P24) 2 3 (Ext)</p> <p>Current Limiter</p> <p>P24</p>	<p><b>Figure 15. PP Output.</b></p> <p>10 VDC (output)</p> <p>10 VDC 10 mA Max.</p> <p>CCA</p> <p>0.047 μf</p> <p>Voltage Regulator</p> <p>P15</p> <p>Use the CCA terminal as the PP signal return.</p>
<p><b>Figure 16. OUT1/OUT2 Output.</b></p> <p>O1A/O2A 2A/120VAC 2A/30VDC</p> <p>O1B/O2B</p> <p>OUT1/OUT2</p> <p>P24 Programmable</p>	<p><b>Figure 17. FP Output.</b></p> <p>1 to 43.2 KHz 50 mA max.</p> <p>P24 Programmable</p> <p>P5 Programmable</p> <p>4.7k</p>
<p><b>Figure 18. AM/FM Output.</b></p> <p>AM 0-10 VDC</p> <p>FM 0-20 mA or 0-10 VDC (see F681)</p> <p>CC</p> <p>0.1 μf</p> <p>Low Pass Filter Circuit</p> <p>P24 Programmable</p> <p>AM = 100 Ω</p> <p>FM = 68 Ω (0-20mA) 120 Ω (0-10VDC)</p>	<p><b>Figure 19. Fault Relay (shown not faulted).</b></p> <p>FLA</p> <p>FLB</p> <p>FLC</p> <p>2A/120VAC 2A/30VDC</p> <p>P24 Programmable</p> <p>F1</p>

# Typical Connection Diagram

Figure 20. The P9 ASD Typical Connection Diagram.

**Note:** When connecting multiple wires to the PA, PB, PC, or PO terminals, do not connect a solid wire and a stranded wire to the same terminal.

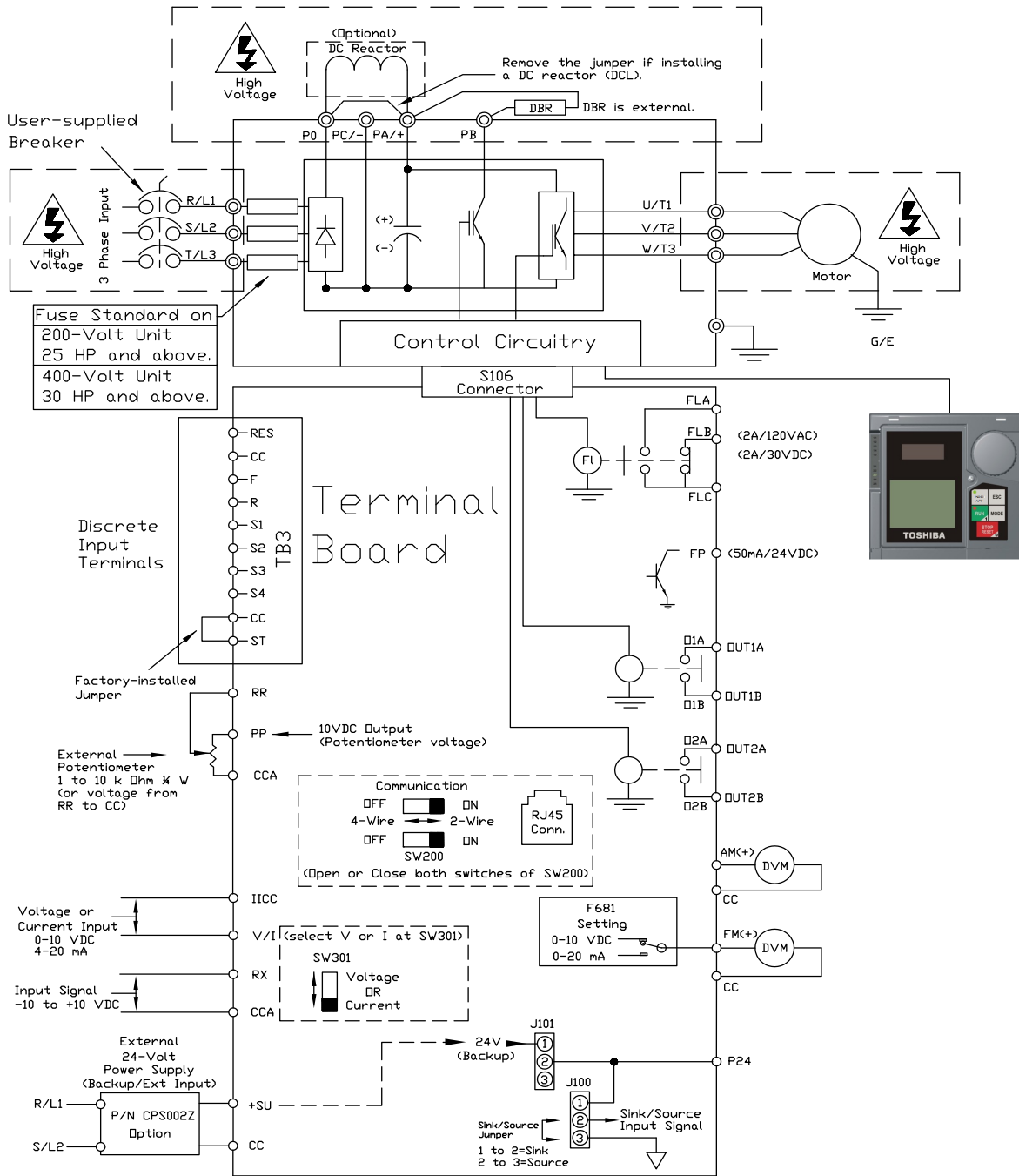

**Note:** The AM, FM, and the +SU analog terminals are referenced to CC. The RR, RX, P24, and the PP analog terminals are referenced to CCA. The isolated V/I analog terminal references IICC.

## Startup and Test



# DANGER

Before turning on the ASD ensure that:

- **R/L1, S/L2, and T/L3** are connected to the 3-phase input power.
- **U/T1, V/T2, and W/T3** are connected to the motor.
- The 3-phase input voltage is within the specified tolerance.
- There are no shorts and all grounds are secured.
- All personnel are at a safe distance from the motor and the motor-driven equipment.

# Electronic Operator Interface

The P9 ASD **Electronic Operator Interface** (EOI) is comprised of an LED screen, an LCD screen, two LEDs, a rotary encoder, and five keys. These items are shown and described on [pg. 26](#).

## EOI Operation

The **EOI** is the primary input/output device for the user. The **EOI** may be used to monitor system functions, input data into the system, perform diagnostics, and view performance data (e.g., motor frequency, bus voltage, torque, etc.).

The software used with the P9 ASD is menu driven; thus, making it a select and click environment. The operating parameters of a motor may be selected and viewed or changed using the **EOI** (or via communications).

## Battery Backup

The EOI is equipped with a battery backup system. The function of the backup system is to retain the EOI SRAM programming in the event of a power outage, or if an EOI removal and installation from one system to another is required without the loss of programming.

Listed below are the items retained by the battery backup system:

[Trip History](#),

[EOI Contrast](#),

[Real-Time Clock](#) Information,

[Monitored Items](#),

[Password and Lockout](#) Information,

[Alarm](#) Information,

[Main Monitor](#) Items,

[Prohibited](#) Items, and

[Save User Settings](#) Information (Parameter settings may be saved by the user).

The battery backup system must be activated by the installer or maintenance personnel to use the backup function.

To activate the battery backup system, remove the Phillips screw from the front of the LED/LCD display unit. Remove the LED/LCD display unit from the ASD. From the circuit side of the display unit, remove the jumper at **J1**, pins **2** and **3**. Place the jumper at **J1**, pins **1** and **2**.

The expected battery life cycle is four and a half years.

**Note:** *The Battery backup system does not supply power to the LED/LCD display.*

## LED/LCD Screen Installation Note

When installing the LED/LCD display unit of the EOI, ensure that the left side of the display is inserted first with the top and bottom catches (see Phillips screws at underside of display) securely in place. This ensures the proper alignment and electrical connection of the CNX connector of the LED/LCD display unit PCB. Gently hold the display in place while securing the Phillips mounting screw.

If improperly seated, the periphery of the LED/LCD display unit will not be flush with the EOI surface and the unit will not function properly.

# EOI Remote Mounting

The EOI may be mounted remotely using the optional **ASD-MTG-KIT9**. The kit contains all of the hardware required to mount the EOI of the 9-Series ASD remotely.

System operation and EOI operation while using the remotely-mounted EOI are the same as with the ASD-mounted configuration.

See the *P9 ASD Installation and Operation Manual* for more information on mounting the EOI remotely.



# EOI Features

Figure 21. The P9 ASD Electronic Operator Interface Features.

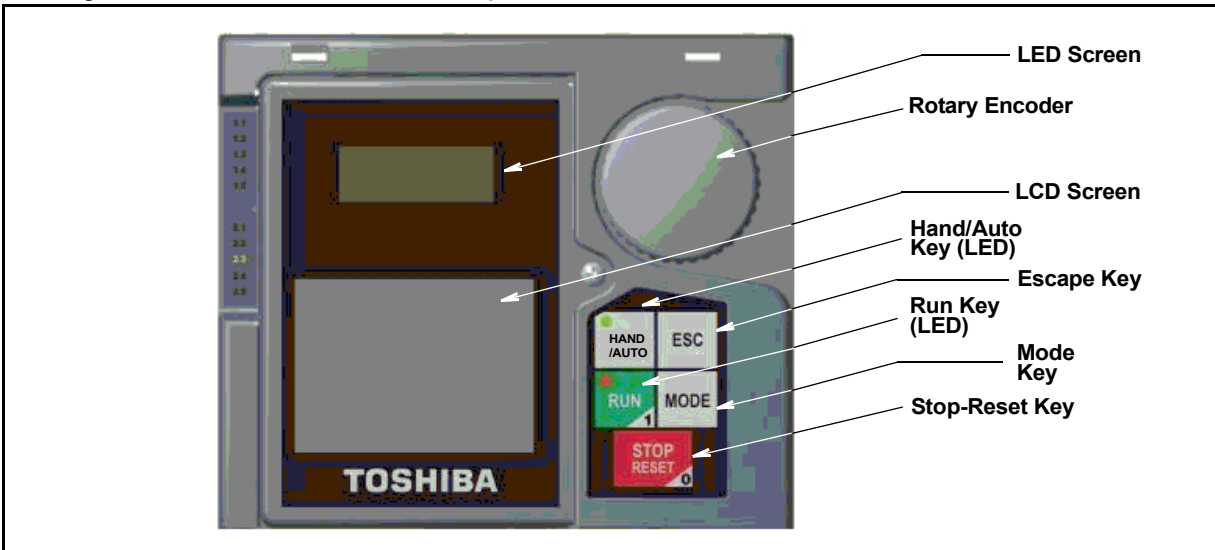

**LED Screen** — Displays the running frequency, active **Fault**, or active **Alarm** information.

**Rotary Encoder** — Used to access the P9 ASD menu selections, change the value of a displayed parameter, and performs the **Enter** key function. Turn the **Rotary Encoder** either clockwise or counterclockwise to perform the **Up** or **Down** functions of the displayed menu selection. Press the **Rotary Encoder** to perform the **Enter** (select) function. Press while turning for times-ten increment/decrement.

**LCD Screen** — Displays configuration information, performance data (e.g., output frequency, bus voltage, torque, etc.), diagnostic information, and **LED** screen information in expanded normal text.

**Hand/Auto Key** — Toggles the system to and from the **Hand** and **Auto** modes. The **Hand/Auto** key is disabled while the **Fault** screen is active. The **Hand/Auto** key LED is on when the system is in the **Hand** mode. The **Hand** mode allows the **Command** and **Frequency** control functions to be carried out via the **EOI**.

The **Auto** mode enables the **Command** and **Frequency** control functions to be carried out via the **Terminal Board**, **RS485**, **Communication Board**, **Pulse Input**, or the settings of F003/F004. The (F003/F004) selection may be made via Program ⇒ Fundamental ⇒ Standard Mode Selection ⇒ [Command Mode](#) and [Frequency Mode 1](#), respectively.

The availability of **Hand** mode control (**Command** and **Frequency** control) may be disabled via Program ⇒ Utilities ⇒ Prohibition ⇒ [Hand/Auto Key Command Override](#) and [Hand/Auto Key Frequency Override](#). The availability of the **Hand** mode of operation may be reinstated by changing this setting or performing a **Reset** (see F007).

**ESC Key** — Returns the system to the previous level of the menu tree, toggles between the **EOI Command** screen and the **Frequency Command** screen, or cancels changes made to a field if pressed while still in the reverse video mode (dark background/light text). The three functions are menu-specific.

**Run Key** — Issues the **Run** command while in the **Hand** mode. The **Run** key LED illuminates green while stopped or red while running to alert personnel.

**Mode Key** — Provides a means to access the three root menus. Pressing the **Mode** key repeatedly loops the system through the three root menus (see [Figure 25 on pg. 29](#)). While looping through the root menus, the **Program** menu will display the root menu screen or the **Program** sub-menu item being accessed prior to pressing the **Mode** key.

**Stop-Reset Key** — This key has three functions.

1. Issues the **Off** command (decelerates to **Stop** at the programmed rate) if pressed once while in the **Hand** mode in accordance with the setting of **F721**.
2. Initiates an **Emergency Off Fault** if pressed twice quickly from the **Hand** or **Auto** modes. The **Emergency Off** function terminates the P9 ASD output and stops the motor in accordance with the setting of **F603**.
3. Resets active **Faults** and/or active **Alarms** if pressed twice quickly. The source of the **Faults** or **Alarms** must be determined and corrected before normal ASD operation can resume.

## LED/LCD Screen

The LED screen is used to display the output frequency, active alarms and/or active faults.

If there are no active alarms or faults, the output frequency is displayed.

During an active alarm, the display toggles to and from the running frequency and the active alarm.

During an active fault, the fault is displayed.

Loss of the **ST-to-CC** connection flashes **Off**.

## LED Character/Font Information

Characters displayed on the LED screen will be of the seven-segment format. Not all alpha-numeric characters are used with the LED screen.

Listed are the seven-segment characters used with the LED screen along with the same characters as they are displayed on the LCD screen.

## LCD Character/Font Information

All alpha-numeric characters are available.

LED/LCD Screen Information			
LED	LCD	LED	LCD
A	A	1	1
b	b	2	2
C	C	3	3
d	d	4	4
E	E	5	5
F	F	6	6
G	G	7	7
H	H	8	8
I	I	9	9
J	J	0	0
L	L		
M	M		
n	n		
O	O		
P	P		
q	q		
r	r		
S	S		
t	t		
U	U		
v	v		
y	y		
-	-		

# LCD Screen

The **LCD** screen is the primary user input/output information center. Parameter settings may be viewed or changed using the LCD display unit of the **EOI**. To view or change a parameter setting using the LCD screen, press the **Mode** key until the **Program** menu is displayed. Turn the **Rotary Encoder** until the desired **Primary Menu** item (see [pg. 34](#)) is within the cursor block. Press the **Rotary Encoder** to select the item from the **Primary Menu** (repeat the press-to-select for submenu items).

See the section titled [Default Setting Changes on pg. 60](#) for more information on changing parameter settings.

Upon reaching the desired parameter selection, the current setting may be viewed, or selected and changed by pressing the **Rotary Encoder** and the setting will take on the reverse video format (dark background/light text). Turn the **Rotary Encoder** to change the parameter setting. Press the **ESC** key while the new parameter setting is in the reverse video mode to exit the selection without saving the change or press the **Rotary Encoder** while the parameter setting is in the reverse video mode to accept the change.

Repeated **ESC** key entries at any time takes the menu back one level each time the **ESC** key is pressed until the **Frequency Command** screen is reached. Further **ESC** entries will toggle the system to and from the **Frequency Command** screen and the **EOI Command** menu.

*Note: Changes carried out from the **EOI Command** screen will be effective for EOI-controlled ASD operation only. See the section titled [EOI Command Mode on pg. 30](#) for further information on **EOI Command Mode** operations.*

## Primary Menus of the LCD Screen

The three primary screens of the LCD screen are displayed while accessing the associated operating mode: the **Frequency Command**, **Monitor**, and the **Program Menu** screens.

Figure 22. **Frequency Command** Screen.

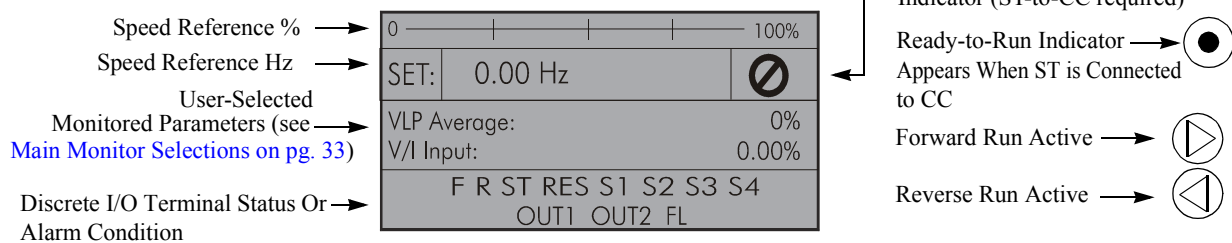

Figure 23. **Monitor** Screen (see [pg. 31](#) for more on the Monitor screen items).

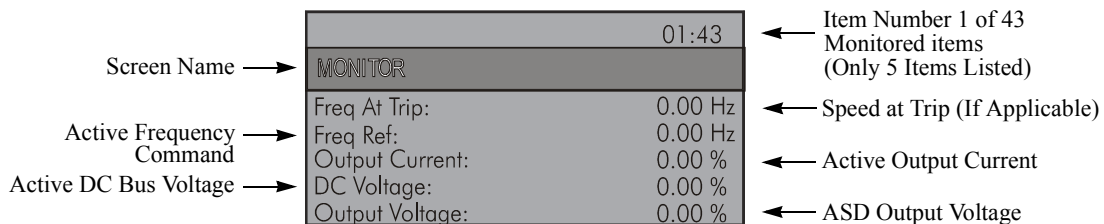
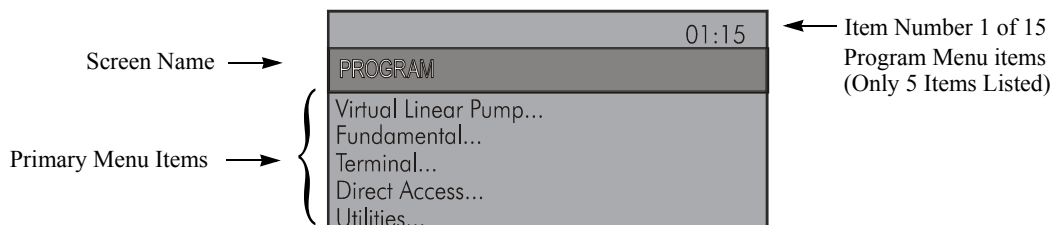

Figure 24. **Program Menu** Screen (see [pg. 34](#) for more on the Program Menu Screen).



# System Configuration and Menu Options

## Root Menus

The **Mode** key accesses the three primary modes of the P9 ASD: the **Frequency Command** mode, the **Monitor** mode, and the **Program** mode. From either mode, press the **Mode** key to loop through to the other two modes (see [Figure 25](#)). While in the **Frequency Command** mode, pressing the **ESC** key toggles the menu to and from the **EOI Command** mode and the **Frequency Command** mode.

The **Alarm** or **Fault** information will be displayed in the event of an active **Alarm** or **Fault**. **Alarm** text will be displayed on the **Frequency Command** screen and on the LED screen when active. **Fault** information will be displayed via the **Fault** screen. See [Alarms and Trips on pg. 66](#) for more information on **Alarms** and **Trips**.

Figure 25. P9 ASD Root Menu Navigation.

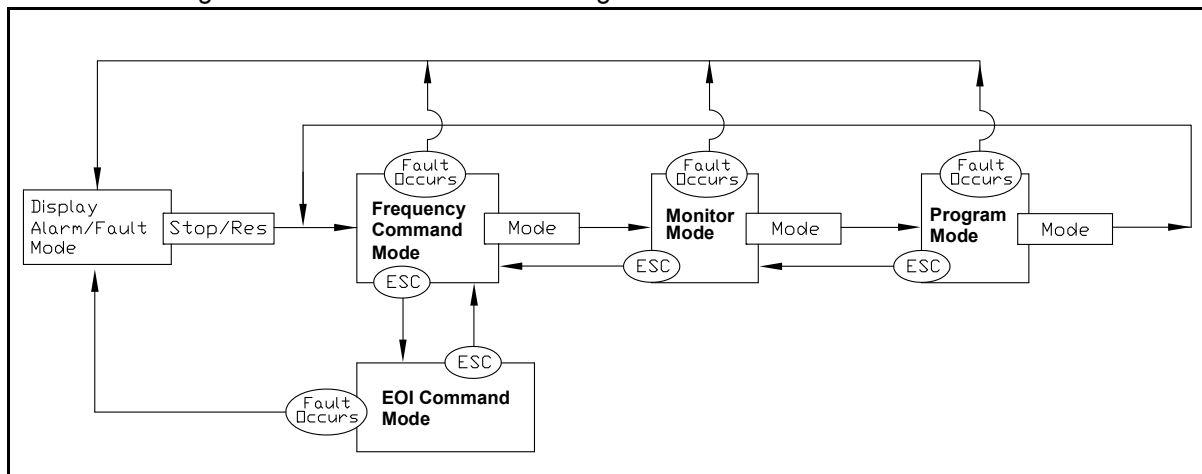

## Frequency Command Mode

### Frequency Setting

While operating in the **Hand** mode (**Hand** LED is illuminated on the EOI), the running frequency of the motor may be set from the **Frequency Command** screen. Using the **Rotary Encoder**, enter the **Frequency Command** value, connect **ST** to **CC**, and provide a **Run** command (F and/or R) and then press the **Run** key. The motor will run at the **Frequency Command** speed and may be changed while running. See [Figure 22 on pg. 28](#) and [Operation \(Hand\) on pg. 59](#) for more information on the **Frequency Command** mode.

# EOI Command Mode

The **EOI Command** mode is accessed by pressing the **ESC** key from the **Frequency Command** screen.

With the exception of the **VLP Control Enable/Disable**, the control settings of the **EOI Command** menu are effective for **EOI** control only.

The **EOI Command** mode provides quick access to the following menu parameters:

**Direction** — **Forward** or **Reverse**.

**Stop Pattern** — The **Decel Stop** or **Coast Stop** setting determines the method used to stop the motor when using the **Stop-Reset** key of the **EOI**. The **Decel Stop** setting enables the **Dynamic Braking** system setup at **F304** or the **DC Injection Braking** system setup at **F250**, **F251**, and **F252**. The **Coast Stop** setting allows the motor to stop at the rate allowed by the inertia of the load.

*Note:* The **Stop Pattern** setting has no effect on the **Emergency Off** settings of **F603**.

**V/f Group** — One of 4 **V/f** profiles may be selected and run. Each **V/f** profile is comprised of 4 user settings: **Base Frequency**, **Base Frequency Voltage**, **Manual Torque Boost**, and **Electronic Thermal Protection**. Expanded descriptions of these parameters may be found in the ***P9 ASD Installation and Operation Manual***.

**Accel/Decel Group** — One of 4 **Accel/Decel** profiles may be selected and run. Each of the **Accel/Decel** profiles is comprised of three user settings: **Acceleration**, **Deceleration**, and **Pattern**. Expanded descriptions of these parameters may be found in the ***P9 ASD Installation and Operation Manual*** (or see **F009**).

**PID Control** — This setting enables or disables the **PID** feedback function.

**Torque Limit Group** — This parameter is used to select 1 of 4 preset positive torque limits to apply to the active motor (of a multiple motor configuration). The settings of profiles 1 – 4 may be set up at **F441**, **F444**, **F446**, and **F448**, respectively.

**VLP Control** — This setting enables or disables the **VLP** function.

# Monitor Mode

The **Monitor** mode allows the user to monitor motor performance variables, control settings, and configuration data during motor operation. There are 43 items that may be monitored from this mode. The items are listed and described below.

*Note:* The **Monitor** mode is a read-only mode. The settings cannot be changed from the **Monitor** mode. For information on how to change the values, see the section titled [Default Setting Changes on pg. 60](#).

*Note:* Any two of the Underlined monitored items may be selected for display at the **Frequency Command** screen while running via *Program* ⇒ *Utilities* ⇒ [Main Monitor Selections](#).

*Note:* The **F701** setting will determine if the **Current** and **Voltage** values displayed appear as **A (Amps)** and **V (Voltage)**, or if the value is shown as a % (percentage) of the **ASD** rating.

**Frequency at Trip** — Displays the at-trip frequency.

**Frequency Reference** — Displays the **Frequency Setpoint**.

**Output Current** — Displays the **Output Current** as a percentage of the rated capacity of the P9 ASD.

**DC Bus Voltage** — Displays the **Bus Voltage** as a percentage of the rated capacity of the P9 ASD.

**Output Voltage** — Displays the **Output Voltage** as a percentage of the rated capacity of the P9 ASD.

**AM Output** — Displays the **AM** output terminal value for the function assigned to the **AM** terminal.

**FM Output** — Displays the **FM** output terminal value for the function assigned to the **FM** terminal.

**Motor OL (Overload) Real** — Displays the real-time **Motor Overload** value as a percentage of the rated capacity of the motor.

**Motor OL (Overload) Trip** — Displays the **Motor Overload Trip** value as a percentage of the rated capacity of the motor.

**Motor Load** — Displays the real-time **Motor Load** as a percentage of the rated capacity of the motor.

**ASD OL (Overload) Real** — Displays the real-time **ASD Overload** as a percentage of the rated capacity of the P9 ASD.

**ASD OL (Overload) Trip** — Displays the **ASD Overload Trip** value as a percentage of the rated capacity of the ASD.

**ASD Load** — Displays the **ASD Load** as a percentage of the rated capacity of the P9 ASD.

**Run Time** — Displays the **Cumulative Run Time** in hours.

**Compensation Frequency** — Displays the **Output Frequency** after the application of the slip compensation correction value (Post Compensation Frequency).

**DBR OL (Overload) Real** — Displays the real-time **DBR Overload** value as a percentage of the **Dynamic Braking Resistor** capacity.

**DBR OL (Overload) Trip** — Displays the **DBR Overload Trip** value as a percentage of the **Dynamic Braking Resistor** capacity.

**DBR Load** — Displays the **DBR Load** as a percentage of the **Dynamic Braking Resistor** capacity.

**Feedback (Inst)** — Provides a status of the **Real Time Feedback** in Hz.

**Feedback (1 Second)** — Provides a status of the **1-Second Averaging** feedback in Hz.

**Torque** — Displays the **Output Torque** as a percentage of the rated capacity of the P9 ASD.

**Torque Reference** — Displays the **Torque Reference** as a percentage of the maximum torque available.

**Torque Current** — Displays the torque-producing current value.

**Excitation Current** — Displays the current value required to produce the excitation field.

**PID Feedback** — Provides a status of the **PID Real Time Feedback** in Hz.

**Input Power** — Displays the **Input Power** in Kilowatts (kW).

**Output Power** — Displays the **Output Power** in Kilowatts (kW).

**Pattern Group Number** — Displays the active **Pattern Run Group Number**.

**Pattern Group Cycle** — Displays the cycle number of the active **Pattern Run Group**.

**Pattern Group Preset** — Displays the active **Preset Speed** being run of the active **Pattern Run Group**.

**Pattern Time** — Displays the remaining time for the active **Pattern Run Group**.

**RR** — Displays the **RR** input value as a percentage of the full range of the **RR** value (potentiometer input).

**V/I** — Displays the **V/I** input setting as a percentage of the full range of the **V/I** value.

*Note: The isolated V/I input terminal may receive **Current** or **Voltage** to control the output speed or the output torque. The input signal type must be selected at **SW301** on the **Terminal Board**.*

*The V input setting of **SW301** is used for the 0 – 10 VDC analog input signal and the I input setting of **SW301** is used for the 0 – 20 mA analog input signal. Either may be used as a frequency or torque command source. See parameter **F201** for more information on the setup of this terminal.*

**RX** — Displays the **RX** input setting as a percentage of the full range of the **RX** value (-10 to +10 VDC input).

**RX2 Option (AI1)** — Displays the **RX2** input setting as a percentage of the full range of the **RX2** value.

*Note: The RX2 function is available on the **Expansion IO Card Option 1** option board (P/N ETB003Z) only.*

**Trip Code** — Displays **None** if there are no errors, or displays one of the associated **Fault Codes** listed in the **P9 ASD Installation and Operation Manual** if there is an active **Fault** (e.g., **E** = **Emergency Off**).

**Past Trip 1** — This function records and displays the last trip incurred. Subsequent trips will replace **Past Trip 1**. As trip records are replaced they are shifted to the next level of the **Past Trip** locations until being deleted (i.e., **Past Trip 1** is moved to **Past Trip 2** and then to **Past Trip 3** until being shifted out of **Past Trip 4**). Once shifted out of **Past Trip 4** the record is deleted. If no trips have occurred since the last reset, **No Error** is displayed for each trip record.

**Past Trip 2** — Past trip information or **None**.

**Past Trip 3** — Past trip information or **None**.

**Past Trip 4** — Past trip information or **None**.

*Note:* An improper P9 ASD setup may cause some trips — reset the P9 ASD to the **Factory Default** settings before pursuing a systemic malfunction (Program ⇒ Utilities ⇒ Type Reset ⇒ **Reset to Factory Settings**).

**Direction** — Displays the **Direction** command (forward/reverse).

**Discrete Input Terminals** — Displays the status (activated = reverse video) of the discrete input terminals of the **Terminal Board**.

**Discrete Output Terminals** — Displays the status (activated = reverse video) of the discrete output lines of the **Terminal Board**.

## Main Monitor Selections

Two (2) **Monitor Mode** items may be selected from the **Main Monitor Selections** screen to be displayed on the **Frequency Command** screen while the P9 ASD is running.

The selected items, along with their real-time values, are displayed on the **Frequency Command** screen while running. Not all **Monitor Mode** items are available for display on the **Frequency Command** screen. The available items are underlined on [pg. 31](#) and [pg. 32](#).

Any two of the underlined items may be selected from the listing at Program ⇒ Utilities ⇒ **Main Monitor Selections**. Select an item from the **Monitor 1** listing and another item from the **Monitor 2** listing to be displayed as shown in [Figure 22 on pg. 28](#) (DC Voltage and Output Current shown).



# Program Mode Menu Navigation

The following table lists the menu items of the **Program** mode and maps the flow of the menu selections. The **Parameter Numbers** for the listed functions are provided where applicable.

The functions listed may be viewed, or selected and changed as mapped below or via the **Direct Access** method: Program ⇒ Direct Access ⇒ *Applicable Parameter Number*.

Program Mode Menu Navigation			
Primary Menu	Sub Menu	Parameter Name	Parameter Number
<b>VIRTUAL LINEAR PUMP</b> (See <a href="#">Virtual Linear Pump</a> on pg. 62 for more on VLP.)	<b>VLP Setup Wizard</b>	VLP Motor/ASD Setup	N/A
		VLP Transducer Setup	
		VLP Setup	
	<b>VLP Settings</b>	VLP Mode Switch	F390
		VLP Application Type	F391
		VLP Application Operating Mode	F380
		VLP Transducer Output Range	F392
		VLP Transducer Maximum Reading	F393
		VLP Minimum	F394
		VLP Maximum	F395
		VLP Command Source	F396
		VLP Command Value	F397
		VLP Low Frequency Limit	F398
	<b>VLP Start and Stop Points</b>	VLP Start and Stop Mode	F385
		VLP Start and Stop Delay Timer	F387
		VLP Low Start and Stop Point	F388
		VLP High Start and Stop Point	F389
		Input Terminal 5 (S1) Function	F115
	<b>VLP Sleep Timer</b>	VLP Sleep Timer	F382
		VLP Sleep Timer Delay	F383
	<b>VLP Run External Devices</b>	VLP External Delay Timer	F480
		VLP External Device Low Band	F481
		VLP External Device High Band	F482
		Output Terminal 1 (OUT1) Function	F130
		Output Terminal 2 (OUT2) Function	F131

<b>Program Mode Menu Navigation</b>			
<b>Primary Menu</b>	<b>Sub Menu</b>	<b>Parameter Name</b>	<b>Parameter Number</b>
<b>VIRTUAL LINEAR PUMP</b>	<b>Low Suction/No-Flow Cut Off</b>	VLP Low Suction/No-Flow Cut Off Mode	F483
		VLP Low Suction/No-Flow Cut Off Delay Timer	F484
		Input Terminal 5 (S1) Function	F115
		Low Suction/No-Flow Cut Off Disposition	F450
	<b>VLP Sealing Water</b>	VLP Sealing Water Mode	F485
		Input Terminal 5 (S1) Function	F115
Output Terminal 1 (OUT1) Function		F130	
<b>FUNDAMENTAL</b>	<b>Accel/Decel 1 Settings</b>	Automatic Acceleration/Deceleration	F000
		Acceleration Time 1	F009
		Deceleration Time 1	F010
		Acceleration/Deceleration Suspended Function	F349
		Acceleration Suspend Frequency	F350
		Acceleration Suspend Time	F351
		Deceleration Suspend Frequency	F352
		Deceleration Suspend Time	F353
	<b>Frequency Settings</b>	Maximum Frequency	F011
		Upper-Limit Frequency	F012
		Lower-Limit Frequency	F013
		V/f Pattern	F015
		Time Limit for Lower-Limit Frequency Operation	F256
	<b>Motor Set 1</b>	Automatic Torque Boost	F001
		Base Frequency 1	F014
		Manual Torque Boost 1	F016
		Motor Overload Protection Level 1	F600
	<b>Standard Mode Selection</b>	Command Mode	F003
		Frequency Mode 1	F004
		Forward/Reverse Run	F008
		Frequency Priority	F200
		Frequency Mode 2	F207
		Frequency Mode Priority Switching Frequency	F208

## Program Mode Menu Navigation

Primary Menu	Sub Menu	Parameter Name	Parameter Number
<b>TERMINAL</b>	<b>Analog Output Terminals</b>	FM Output Terminal Function	F005
		FM Output Terminal Adjustment	F006
		FM Output Gradient Characteristic	F682
		FM Bias Adjustment	F683
		FM Voltage/Current Output Switching	F681
		AM Output Terminal Function	F670
		AM Output Terminal Adjustment	F671
		AM Output Gradient Characteristic	F685
		AM Bias Adjustment	F686
		MON 1 Terminal Meter Selection	F672
		MON 1 Terminal Meter Adjustment	F673
		MON 1 Output Gradient Characteristic	F689
		MON 1 Bias Adjustment	F690
		MON 1 Voltage/Current Output Switching	F688
		MON 2 Terminal Meter Selection	F674
		MON 2 Terminal Meter Adjustment	F675
		MON 2 Output Gradient Characteristic	F692
		MON 2 Bias Adjustment	F693
		MON 2 Voltage/Current Output Switching	F691
		FP Terminal Assignment	F676
	FP Terminal Frequency	F677	
	<b>Input Special Functions</b>	Forward/Reverse Run Priority When Both Are Activated	F105
		Input Terminal Priority	F106
		16-Bit Binary/BCD Input	F107
		V/I Analog Input Broken Wire Detection Level	F633
	<b>Input Terminal Delays</b>	Input Terminal 1 (F) Response Time	F140
		Input Terminal 2 (R) Response Time	F141
		Input Terminal 3 (ST) Response Time	F142
		Input Terminal 4 (RES) Response Time	F143
		Input Terminal 5–12 Response Time	F144

## Program Mode Menu Navigation

Primary Menu	Sub Menu	Parameter Name	Parameter Number	
<b>TERMINAL</b>	<b>Input Terminal Delays</b>	Input Terminal 13–20 Response Time	F145	
		Always ON Terminal Function	F110	
	<b>Input Terminals</b>	Input Terminal 1 (F) Function	F111	
		Input Terminal 2 (R) Function	F112	
		Input Terminal 3 (ST) Function	F113	
		Input Terminal 4 (RES) Function	F114	
		Input Terminal 5 (S1) Function	F115	
		Input Terminal 6 (S2) Function	F116	
		Input Terminal 7 (S3) Function	F117	
		Input Terminal 8 (S4) Function	F118	
		Input Terminal 9 (LI1) Function	F119	
		Input Terminal 10 (LI2) Function	F120	
		Input Terminal 11 (LI3) Function	F121	
		Input Terminal 12 (LI4) Function	F122	
		Input Terminal 13 (LI5) Function	F123	
		Input Terminal 14 (LI6) Function	F124	
		Input Terminal 15 (LI7) Function	F125	
		Input Terminal 16 (LI8) Function	F126	
		Input Terminal 17 (B12) Function	F164	
		Input Terminal 18 (B13) Function	F165	
		Input Terminal 19 (B14) Function	F166	
		Input Terminal 20 (BI5) Function	F167	
		Virtual Input Terminal Selection 1	F973	
		Virtual Input Terminal Selection 2	F974	
		Virtual Input Terminal Selection 3	F975	
		Virtual Input Terminal Selection 4	F976	
		<b>Line Power Switching</b>	Commercial Power/ASD Switching Output	F354
			Commercial Power/ASD Switching Frequency	F355
			ASD Side Switching Delay	F356
			Commercial Power-Side Switching Delay	F357
	Commercial Power Switching Frequency Hold Time		F358	

<b>Program Mode Menu Navigation</b>			
<b>Primary Menu</b>	<b>Sub Menu</b>	<b>Parameter Name</b>	<b>Parameter Number</b>
<b>TERMINAL</b>	<b>Output Terminals</b>	Output Terminal 1 (OUT1) Function	F130
		Output Terminal 2 (OUT2) Function	F131
		Output Terminal 3 (FL) Function	F132
		Output Terminal 4 (OUT3) Function	F133
		Output Terminal 5 (OUT4) Function	F134
		Output Terminal 6 (R1) Function	F135
		Output Terminal 7 (OUT5) Function	F136
		Output Terminal 8 (OUT6) Function	F137
		Output Terminal 9 (R2) Function	F138
		Output Terminal 10 (R3) Function	F168
	Output Terminal 11 (R4) Function	F169	
	<b>Reach Settings</b>	Low-Speed Signal Output Frequency	F100
		Speed Reach Frequency	F101
Speed Reach Detection Band		F102	
<b>DIRECT ACCESS</b>	Parameter Number Input	N/A	
	Unknown Numbers Accepted		
<b>UTILITIES</b>	<b>Version</b>	EOI / ASD Type / CPU / EEPROM / MC Level	N/A
	<b>Display Parameters</b>	Automatic Function Selection	F040
		Current/Voltage Display Units	F701
		Free Unit Multiplication Factor	F702
		Free Unit	F703
		Free Unit Display Gradient Characteristic	F705
		Free Unit Display Bias	F706
		Change Step Selection 1	F707
		Change Step Selection 2	F708
	<b>Prohibition</b>	Write Parameter Lock Out	F700
		Command Mode/Frequency Mode Lock Out	F736
		Lock Out All Keys	F737
		Hand/Auto Key Command Override	N/A
		Hand/Auto Key Frequency Override	

Program Mode Menu Navigation			
Primary Menu	Sub Menu	Parameter Name	Parameter Number
<b>UTILITIES</b>	<b>Alarm Prohibition (prohibits an EOI alarm display ONLY — alarm still activated)</b>	Show Uninitialized Parameters at Changed From Default Screen	N/A
		Over-Current Alarm	
		ASD Overload Alarm	
		Motor Overload Alarm	
		Over-Heat Alarm	
		Over-Voltage Alarm	
		Main Power Under-Voltage Alarm	
		Reserved (POFF) Alarm	
		Under-Current Alarm	
		(Approaching) Over-Torque Alarm Threshold	
		Dynamic Braking Resistor (DBR) Overload Alarm	
		Cumulative Run Timer Alarm	
		DeviceNet/Profibus/CC-Link Alarm	
		RS485 Communication	
		Main Power Under-Voltage Alarm	
		Stop After Instantaneous Power-Off Alarm	
		Stop After Lower-Limit Continuous Time	
		Light-Load Alarm	
		Heavy-Load Alarm	
		Maintenance Timer Alarm	
	Over-Torque Alarm		
	Soft Stall Alarm		
	VLP Low Suction/No-Flow Cut Off Alarm		
	<b>Type Reset</b>	Reset Selections	F007
<b>Real-Time Clock Setup</b>	Set Real-Time Clock	N/A	
<b>Trip History (read-only)</b>	Trip Number	N/A	
	Trip Type		
	Frequency at Trip		
	Output Current		

Program Mode Menu Navigation			
Primary Menu	Sub Menu	Parameter Name	Parameter Number
<b>UTILITIES</b>	<b>Trip History (read-only)</b>	Output Voltage	N/A
		Direction	
		Frequency Reference	
		DC Voltage	
		Discrete Input Terminals	
		Discrete Output Terminals	
		Run Timer	
		Post Compensation Frequency	
		Speed Feedback (Real-Time)	
		Speed Feedback (1 Second)	
		Torque Feedback	
		Torque Reference	
		Torque Current	
		Excitation Current	
		PID Feedback	
		Motor Overload Ratio	
		ASD Overload Ratio	
		Dynamic Braking Resistor (DBR) Overload Ratio	
		Motor Load	
		ASD Load	
		Dynamic Braking Resistor (DBR) Load	
	Input Power		
	Output Power		
	<b>Changed From Default</b>	Display Changed Parameters	N/A
	<b>Contrast</b>	Contrast Adjustment	N/A
	<b>Main Monitor Selections</b>	Monitor 1	N/A
		Monitor 2	
	<b>Trace</b>	Trace Selection	F740
Trace Cycle		F741	
Trace Data 1		F742	

<b>Program Mode Menu Navigation</b>			
<b>Primary Menu</b>	<b>Sub Menu</b>	<b>Parameter Name</b>	<b>Parameter Number</b>
<b>UTILITIES</b>	<b>Trace</b>	Trace Data 2	F743
		Trace Data 3	F744
		Trace Data 4	F745
	<b>View Trace Data</b>	View Trace Data	N/A
	<b>Save/Restore Wizard</b>	Save/Restore System Settings	
<b>PROTECTION</b>	<b>Abnormal Speed Settings</b>	Abnormal Speed Detection Time	F622
		Over-Speed Detection Frequency Upper Band	F623
		Over-Speed Detection Frequency Lower Band	F624
	<b>Base Frequency Voltage</b>	Supply Voltage Correction	F307
	<b>DC Injection Braking</b>	DC Injection Braking Start Frequency	F250
		DC Injection Braking Current	F251
		DC Injection Braking Time	F252
		Forward/Reverse DC Injection Braking Priority	F253
		Motor Shaft Stationary Control	F254
	<b>Dynamic Braking</b>	Dynamic Braking Selection	F304
		Dynamic Braking Resistance	F308
		Continuous Dynamic Braking Capacity	F309
		Braking Resistance Overload Time (10x Rated Torque)	F639
	<b>Emergency Off Settings</b>	Emergency Off	F603
		Emergency DC Injection Braking Control Time	F604
	<b>Low-Current Settings</b>	Low-Current Trip	F610
		Low-Current Detection Current	F611
		Low-Current Detection Time	F612
		Low-Current Detection Hysteresis Width	F609
	<b>Overload</b>	Motor Overload Protection Configuration	F017
		Overload Reduction Start Frequency	F606
		Motor 150% Overload Time Limit	F607
		ASD Overload	F631
	<b>Over-Torque Parameters</b>	Over-Torque Trip	F615



<b>Program Mode Menu Navigation</b>			
<b>Primary Menu</b>	<b>Sub Menu</b>	<b>Parameter Name</b>	<b>Parameter Number</b>
<b>PROTECTION</b>	<b>Over-Torque Parameters</b>	Over-Torque Detection Level During Power Running	F616
		Over-Torque Detection Level During Regenerative Braking	F617
		Over-Torque Detection Time	F618
		Over-Torque Detection Hysteresis	F619
	<b>Phase Loss</b>	ASD Output Phase Loss Detection	F605
		ASD Input Phase Loss Detection	F608
	<b>Retry/Restart</b>	Auto Restart Selection	F301
		Number of Times to Retry	F303
		Ridethrough Time	F310
		Random Mode	F312
	<b>Stall</b>	Over-Voltage Limit Operation	F305
		Stall Prevention Factor 1	F416
		Power Running Stall Continuous Trip Detection Time	F452
		Stall Prevention During Regeneration	F453
		Stall Prevention Level	F601
		Over-Voltage Limit Operation Level	F626
	<b>Trip Settings</b>	Retain Trip Record at Power Down	F602
	<b>Under-Voltage/ Ridethrough</b>	Regenerative Power Ridethrough Mode	F302
		Synchronized Deceleration Time	F317
		Synchronized Acceleration Time	F318
		Under-Voltage Trip	F627
		Under-Voltage (Trip Alarm) Detection Time	F628
		Regenerative Power Ridethrough Control Level	F629
	<b>Special Protection Parameters</b>	Short Circuit Detection at Start	F613
		Cooling Fan Control	F620
		Cumulative Operation Time Alarm Setting	F621
		Brake Answer Delay	F630
<b>FREQUENCY</b>	<b>Analog Filter</b>	Analog Input Filter	F209

<b>Program Mode Menu Navigation</b>			
<b>Primary Menu</b>	<b>Sub Menu</b>	<b>Parameter Name</b>	<b>Parameter Number</b>
<b>FREQUENCY</b>	<b>Forward/Reverse Disable</b>	Forward/Reverse Disable	F311
	<b>Jog Settings</b>	Jog Frequency	F260
		Jog Stop Pattern	F261
		EOI Operation Jog Mode	F262
	<b>UP/DOWN Frequency Functions</b>	UP/DOWN Up Response Time	F264
		UP/DOWN Up Frequency Step	F265
		UP/DOWN Down Response Time	F266
		UP/DOWN Down Frequency Step	F267
		Initial UP/DOWN Frequency	F268
		Initial UP/DOWN Frequency Rewriting	F269
	<b>V/I Settings</b>	Option V/I Terminal Voltage/Current Selection (AI2 Option Board Input)	F109
	<b>Preset Speeds</b>	Preset Speed 1	F018
		Preset Speed 2	F019
		Preset Speed 3	F020
		Preset Speed 4	F021
		Preset Speed 5	F022
		Preset Speed 6	F023
		Preset Speed 7	F024
		Preset Speed 8	F287
		Preset Speed 9	F288
		Preset Speed 10	F289
		Preset Speed 11	F290
		Preset Speed 12	F291
		Preset Speed 13	F292
		Preset Speed 14	F293
		Preset Speed 15	F294
	<b>Speed Reference Setpoints</b>	V/I Input Point 1 Setting	F201
V/I Input Point 1 Frequency		F202	
V/I Input Point 2 Setting		F203	

## Program Mode Menu Navigation

Primary Menu	Sub Menu	Parameter Name	Parameter Number
<b>FREQUENCY</b>	<b>Speed Reference Setpoints</b>	V/I Input Point 2 Frequency	F204
		RR Input Point 1 Setting	F210
		RR Input Point 1 Frequency	F211
		RR Input Point 2 Setting	F212
		RR Input Point 2 Frequency	F213
		RX Input Point 1 Setting	F216
		RX Input Point 1 Frequency	F217
		RX Input Point 2 Setting	F218
		RX Input Point 2 Frequency	F219
		RX2 Option (AI1) Input Point 1 Setting	F222
		RX2 Option (AI1) Input Point 1 Frequency	F223
		RX2 Option (AI1) Input Point 2 Setting	F224
		RX2 Option (AI1) Input Point 2 Frequency	F225
		BIN Input Point 1 Setting	F228
		BIN Input Point 1 Frequency	F229
		BIN Input Point 2 Setting	F230
		BIN Input Point 2 Frequency	F231
		PG Input Point 1 Setting	F234
		PG Input Point 1 Frequency	F235
		PG Input Point 2 Setting	F236
		PG Input Point 2 Frequency	F237
		V/I Input Bias	F470
		V/I Input Gain	F471
		RR Input Bias	F472
		RR Input Gain	F473
		RX Input Bias	F474
		RX Input Gain	F475
		RX2 Option (AI1) Input Bias	F476
		RX2 Option (AI1) Input Gain	F477
		V/I Input Bias (AI2 Option Board Input)	F478
V/I Input Gain (AI2 Option Board Input)	F479		

## Program Mode Menu Navigation

Primary Menu	Sub Menu	Parameter Name	Parameter Number
<b>SPECIAL</b>	<b>Acc/Dec 1 – 4 Settings</b>	Acceleration Time 2	F500
		Deceleration Time 2	F501
		Acceleration/Deceleration Pattern 1	F502
		Acceleration/Deceleration Pattern 2	F503
		Acceleration Time 3	F510
		Deceleration Time 3	F511
		Acceleration/Deceleration Pattern 3	F512
		Acceleration Time 4	F514
		Deceleration Time 4	F515
		Acceleration/Deceleration Pattern 4	F516
	<b>Acc/Dec Special</b>	Acceleration/Deceleration Pattern 1 – 4	F504
		Acceleration/Deceleration Switching Frequency 1	F505
		S-Pattern Acceleration Lower-Limit Adjustment	F506
		S-Pattern Acceleration Upper-Limit Adjustment	F507
		S-Pattern Deceleration Lower-Limit Adjustment	F508
		S-Pattern Deceleration Upper-Limit Adjustment	F509
		Acceleration/Deceleration Switching Frequency 2	F513
		Acceleration/Deceleration Switching Frequency 3	F517
	<b>Carrier Frequency</b>	PWM Carrier Frequency	F300
		Carrier Frequency Control Mode	F316
	<b>V/f 5-Point Setting</b>	V/f 5-Point Setting Frequency 1	F190
		V/f 5-Point Setting Voltage 1	F191
		V/f 5-Point Setting Frequency 2	F192
		V/f 5-Point Setting Voltage 2	F193
		V/f 5-Point Setting Frequency 3	F194
		V/f 5-Point Setting Voltage 3	F195
		V/f 5-Point Setting Frequency 4	F196
		V/f 5-Point Setting Voltage 4	F197
		V/f 5-Point Setting Frequency 5	F198
		V/f 5-Point Setting Voltage 5	F199

<b>Program Mode Menu Navigation</b>			
<b>Primary Menu</b>	<b>Sub Menu</b>	<b>Parameter Name</b>	<b>Parameter Number</b>
<b>SPECIAL</b>	<b>Frequency Control</b>	Start Frequency	F240
		Run Frequency	F241
		Run Frequency Hysteresis	F242
		End Frequency	F243
	<b>Special Parameters</b>	0 Hz Dead Band Signal	F244
		0 Hz Command Output	F255
		Exciting Strengthening Coefficient	F415
		Annual Average Ambient Temperature	F634
		Rush Current Suppression Relay Activation Time	F635
		PTC 1 Thermal Selection	F637
		PTC 2 Thermal Selection	F638
	<b>Jump Frequencies</b>	Jump Frequency 1	F270
		Jump Frequency 1 Bandwidth	F271
		Jump Frequency 2	F272
		Jump Frequency 2 Bandwidth	F273
		Jump Frequency 3	F274
		Jump Frequency 3 Bandwidth	F275
	<b>Operation Panel Parameters</b>	Operation Command Clear Selection When Standby Terminal is Off	F719
		Panel Stop Pattern	F721
		Panel Torque Command	F725
		Panel Tension Torque Bias	F727
		Panel Load Sharing Gain	F728
		Panel Override Multiplication Gain	F729
		Panel Frequency Lock Out	F730
Panel Emergency Off Lock Out		F734	
Panel Reset Lock Out		F735	
<b>MOTOR</b>	<b>Motor Set 2</b>	Motor Set 2 Base Frequency	F170
		Motor Set 2 Base Frequency Voltage	F171
		Motor Set 2 Manual Torque Boost	F172
		Motor Set 2 Overload Protection Level	F173

Program Mode Menu Navigation			
Primary Menu	Sub Menu	Parameter Name	Parameter Number
<b>MOTOR</b>	<b>Motor Set 3</b>	Motor Set 3 Base Frequency	F174
		Motor Set 3 Base Frequency Voltage	F175
		Motor Set 3 Manual Torque Boost	F176
		Motor Set 3 Overload Protection Level	F177
	<b>Motor Set 4</b>	Motor Set 4 Base Frequency	F178
		Motor Set 4 Base Frequency Voltage	F179
		Motor Set 4 Manual Torque Boost	F180
		Motor Set 4 Overload Protection Level	F181
	<b>PM Motor</b>	PM Motor Constant 1 (D-Axis Inductance)	F498
		PM Motor Constant 2 (Q-Axis Inductance)	F499
		Step-Out Detection-Current Level (For PM Motors)	F640
		Step-Out Detection-Current Time (For PM Motors)	F641
	<b>Vector Motor Model</b>	Autotune 1	F400
		Slip Frequency Gain	F401
		Autotune 2	F402
		Motor Rated Capacity (Nameplate)	F405
		Motor Rated Current (Nameplate)	F406
		Motor Rated RPM (Nameplate)	F407
		Base Frequency Voltage 1	F409
		Motor Constant 1 (Torque Boost)	F410
		Motor Constant 2 (No Load Current)	F411
		Motor Constant 3 (Leak Inductance)	F412
Motor Constant 4 (Rated Slip)		F413	
<b>TORQUE</b>	<b>Manual Torque Limit Settings</b>	Power Running Torque Limit 2 Level	F444
		Regenerative Braking Torque Limit 2 Level	F445
		Power Running Torque Limit 3 Level	F446
		Regenerative Braking Torque Limit 3 Level	F447
		Power Running Torque Limit 4 Level	F448
		Regenerative Braking Torque Limit 4 Level	F449
	<b>Setpoints</b>	V/I Input Point 1 Rate	F205

## Program Mode Menu Navigation

Primary Menu	Sub Menu	Parameter Name	Parameter Number
<b>TORQUE</b>	<b>Setpoints</b>	V/I Input Point 2 Rate	F206
		RR Input Point 1 Rate	F214
		RR Input Point 2 Rate	F215
		RX Input Point 1 Rate	F220
		RX Input Point 2 Rate	F221
		RX2 Option (AI1) Input Point 1 Rate	F226
		RX2 Option (AI1) Input Point 2 Rate	F227
	<b>Torque Control</b>	Braking Mode	F341
		Torque Bias Input	F342
		Panel Torque Bias	F343
		Panel Torque Gain	F344
		Release Time	F345
		Creeping Frequency	F346
		Creeping Time	F347
		Braking Time Learning Function	F348
		Torque Command	F420
		Tension Torque Bias Input (Torque Control)	F423
		Load Sharing Gain Input	F424
		Forward Speed Limit Input	F425
		Forward Speed Limit Input Level	F426
		Reverse Speed Limit Input	F427
	Reverse Speed Limit Input Level	F428	
	<b>Torque Limit Settings</b>	Power Running Torque Limit 1	F440
		Power Running Torque Limit 1 Level	F441
		Regenerative Braking Torque Limit 1	F442
		Regenerative Braking Torque Limit 1 Level	F443
		Acceleration/Deceleration Operation After Torque Limit	F451
	<b>Torque Speed Limiting</b>	Speed Limit (Torque = 0) Center Value Reference	F430
		Speed Limit (Torque = 0) Center Value	F431
		Speed Limit (Torque = 0) Band	F432
		Allow Rotation in Specified Direction ONLY	F435

<b>Program Mode Menu Navigation</b>			
<b>Primary Menu</b>	<b>Sub Menu</b>	<b>Parameter Name</b>	<b>Parameter Number</b>
<b>FEEDBACK</b>	<b>Drooping Control</b>	Drooping Gain	F320
		Speed at 0% Drooping Gain	F321
		Speed at <b>F320</b> Drooping Gain	F322
		Drooping Insensitive Torque	F323
		Drooping Output Filter	F324
	<b>Feedback Settings</b>	PID Control Switching	F359
		PID Feedback Signal	F360
		PID Feedback Delay Filter	F361
		PID Feedback Proportional Gain	F362
		PID Feedback Integral Gain	F363
		PID Deviation Upper-Limit	F364
		PID Deviation Lower-Limit	F365
		PID Feedback Differential Gain	F366
		Process Upper-Limit	F367
		Process Lower-Limit	F368
		PID Control Delay	F369
		PID Output Upper-Limit	F370
		PID Output Lower-Limit	F371
		Process Increasing Rate	F372
		Process Decreasing Rate	F373
	Speed PI Switching Frequency	F466	
	<b>Override Control</b>	Adding Input Selection	F660
		Multiplying Input Selection	F661
	<b>PG Settings</b>	Number of PG Input Pulses	F375
		Number of PG Input Phases	F376
		PG Disconnection Detection	F377
		Simple Positioning Completion Range	F381
		Current Control Proportional Gain	F458
		Speed Loop Proportional Gain	F460
		Speed Loop Stabilization Coefficient	F461



<b>Program Mode Menu Navigation</b>			
<b>Primary Menu</b>	<b>Sub Menu</b>	<b>Parameter Name</b>	<b>Parameter Number</b>
<b>FEEDBACK</b>	<b>PG Settings</b>	Load Moment of Inertia 1	F462
		Second Speed Loop Proportional Gain	F463
		Second Speed Loop Stabilization Coefficient	F464
		Load Moment of Inertia 2	F465
<b>MY FUNCTION</b>	<b>My Function Selection</b>	My Function Operating Mode	F977
	<b>My Function Unit 1</b>	Input Function Target 1	F900
		Input Function Command 1	F901
		Input Function Target 2	F902
		Input Function Command 2	F903
		Input Function Target 3	F904
		Output Function Assigned	F905
	<b>My Function Unit 2</b>	Input Function Target 1	F906
		Input Function Command 1	F907
		Input Function Target 2	F908
		Input Function Command 2	F909
		Input Function Target 3	F910
		Output Function Assigned	F911
	<b>My Function Unit 3</b>	Input Function Target 1	F912
		Input Function Command 1	F913
		Input Function Target 2	F914
		Input Function Command 2	F915
		Input Function Target 3	F916
		Output Function Assigned	F917
	<b>My Function Unit 4</b>	Input Function Target 1	F935
		Input Function Command 1	F936
		Input Function Target 2	F937
		Input Function Command 2	F938
		Input Function Target 3	F939
		Output Function Assigned	F940
	<b>My Function Unit 5</b>	Input Function Target 1	F941

<b>Program Mode Menu Navigation</b>			
<b>Primary Menu</b>	<b>Sub Menu</b>	<b>Parameter Name</b>	<b>Parameter Number</b>
<b>MY FUNCTION</b>	<b>My Function Unit 5</b>	Input Function Command 1	F942
		Input Function Target 2	F943
		Input Function Command 2	F944
		Input Function Target 3	F945
		Output Function Assigned	F946
	<b>My Function Unit 6</b>	Input Function Target 1	F947
		Input Function Command 1	F948
		Input Function Target 2	F949
		Input Function Command 2	F950
		Input Function Target 3	F951
		Output Function Assigned	F952
	<b>My Function Unit 7</b>	Input Function Target 1	F953
		Input Function Command 1	F954
		Input Function Target 2	F955
		Input Function Command 2	F956
		Input Function Target 3	F957
		Output Function Assigned	F958
	<b>My Function Data</b>	My Function Percent Data 1	F918
		My Function Percent Data 2	F919
		My Function Percent Data 3	F920
		My Function Percent Data 4	F921
		My Function Percent Data 5	F922
		My Function Frequency Data 1	F923
		My Function Frequency Data 2	F924
		My Function Frequency Data 3	F925
		My Function Frequency Data 4	F926
		My Function Frequency Data 5	F927
		My Function Time Data 1	F928
		My Function Time Data 2	F929
		My Function Time Data 3	F930

<b>Program Mode Menu Navigation</b>			
<b>Primary Menu</b>	<b>Sub Menu</b>	<b>Parameter Name</b>	<b>Parameter Number</b>
<b>MY FUNCTION</b>	<b>My Function Data</b>	My Function Time Data 4	F931
		My Function Time Data 5	F932
		My Function Count Data 1	F933
		My Function Count Data 2	F934
	<b>My Function Analog</b>	Analog Input Function Target 11	F959
		Analog Function Assigned Object 11	F961
		Analog Input Function Target 21	F962
		Analog Function Assigned Object 21	F964
	<b>My Function Monitor</b>	Monitor Output Function 11 (2000–3099=FD00–FE99)	F965
		Monitor Output Function Command 11	F966
		Monitor Output Function 21 (2000–3099=FD00–FE99)	F967
		Monitor Output Function Command 21	F968
		Monitor Output Function 31 (2000–3099=FD00–FE99)	F969
		Monitor Output Function Command 31	F970
		Monitor Output Function 41 (2000–3099=FD00–FE99)	F971
		Monitor Output Function Command 41	F972
	<b>COMMUNICATIONS</b>	<b>Communication Adjustments</b>	Frequency Point Selection
Point 1 Setting			F811
Point 1 Frequency			F812
Point 2 Setting			F813
Point 2 Frequency			F814
<b>Communication Settings</b>		Baud Rate (2-Wire RS485)	F800
		Parity (2-Wire and 4-Wire RS485)	F801
		ASD Number	F802
		Communications Time-Out (2-Wire and 4-Wire RS485)	F803
		Communication Time-Out Action (2-Wire and 4-Wire RS485)	F804
		Send Delay (2-Wire RS485)	F805
		ASD-to-ASD Communication (2-Wire RS485)	F806
		Baud Rate (4-Wire RS485)	F820
		RS485 Send Delay (4-Wire RS485)	F825

## Program Mode Menu Navigation

Primary Menu	Sub Menu	Parameter Name	Parameter Number
<b>COMMUNICATIONS</b>	<b>Communication Settings</b>	ASD-to-ASD Communication (4-Wire RS485)	F826
		4-Wire RS485 Protocol (TSB/MODBUS)	F829
		Communication Option (DeviceNet/Profibus) Setting 1	F830
		Communication Option (DeviceNet/Profibus) Setting 2	F831
		Communication Option (DeviceNet/Profibus) Setting 3	F832
		Communication Option (DeviceNet/Profibus) Setting 4	F833
		Communication Option (DeviceNet/Profibus) Setting 5	F834
		Communication Option (DeviceNet/Profibus) Setting 6	F835
		Communication Option (DeviceNet/Profibus) Setting 7	F836
		Communication Option (DeviceNet/Profibus) Setting 8	F841
		Communication Option (DeviceNet/Profibus) Setting 9	F842
		Communication Option (DeviceNet/Profibus) Setting 10	F843
		Communication Option (DeviceNet/Profibus) Setting 11	F844
		Communication Option (DeviceNet/Profibus) Setting 12	F845
		Communication Option (DeviceNet/Profibus) Setting 13	F846
		Disconnection Detection Extended Time	F850
		ASD Operation at Disconnection	F851
		Preset Speed Operation	F852
		Communication Option Station Address Monitor	F853
		Communication Option Speed Switch Monitor DeviceNet/CC-Link	F854
		Block Write Data 1	F870
		Block Write Data 2	F871
		Block Read Data 1	F875
		Block Read Data 2	F876
		Block Read Data 3	F877
		Block Read Data 4	F878
Block Read Data 5	F879		
Free Notes	F880		
Network Option Reset Setting	F899		

Program Mode Menu Navigation			
Primary Menu	Sub Menu	Parameter Name	Parameter Number
<b>COMMUNICATIONS</b>	<b>Ethernet Settings</b>	IP	N/A
		Sub Net	
		Gateway	
		DHCP Mode	
		MAC ID	
<b>PATTERN RUN</b>	<b>Operation Mode</b>	Preset Speed Operation Mode	F560
		<b>Preset Speed 1</b>	F561
		Direction	
		Acceleration/Deceleration Group	
		V/f Group	
		Torque Limit Group	
		<b>Preset Speed 2</b>	F562
		Direction	
		Acceleration/Deceleration Group	
		V/f Group	
		Torque Limit Group	
		<b>Preset Speed 3</b>	F563
		Direction	
		Acceleration/Deceleration Group	
		V/f Group	
		Torque Limit Group	
		<b>Preset Speed 4</b>	F564
		Direction	
		Acceleration/Deceleration Group	
		V/f Group	
Torque Limit Group			
<b>Preset Speed 5</b>	F565		
Direction			
Acceleration/Deceleration Group			
V/f Group			

Program Mode Menu Navigation			
Primary Menu	Sub Menu	Parameter Name	Parameter Number
<b>PATTERN RUN</b>	<b>Operation Mode</b>	Torque Limit Group	F565
		<b>Preset Speed 6</b>	F566
		Direction	
		Acceleration/Deceleration Group	
		V/f Group	F566
		Torque Limit Group	
		<b>Preset Speed 7</b>	F567
		Direction	
		Acceleration/Deceleration Group	
		V/f Group	
		Torque Limit Group	
		<b>Preset Speed 8</b>	F568
		Direction	
		Acceleration/Deceleration Group	
		V/f Group	
		Torque Limit Group	
		<b>Preset Speed 9</b>	F569
		Direction	
		Acceleration/Deceleration Group	
		V/f Group	
		Torque Limit Group	
		<b>Preset Speed 10</b>	F570
		Direction	
		Acceleration/Deceleration Group	
		V/f Group	
		Torque Limit Group	
		<b>Preset Speed 11</b>	F571
		Direction	
		Acceleration/Deceleration Group	
		V/f Group	

Program Mode Menu Navigation			
Primary Menu	Sub Menu	Parameter Name	Parameter Number
<b>PATTERN RUN</b>	<b>Operation Mode</b>	Torque Limit Group	F571
		<b>Preset Speed 12</b>	
		Direction	F572
		Acceleration/Deceleration Group	
		V/f Group	F572
		Torque Limit Group	
		<b>Preset Speed 13</b>	
		Direction	F573
		Acceleration/Deceleration Group	
		V/f Group	
		Torque Limit Group	
		<b>Preset Speed 14</b>	
		Direction	F574
		Acceleration/Deceleration Group	
		V/f Group	
		Torque Limit Group	
		<b>Preset Speed 15</b>	
		Direction	F575
		Acceleration/Deceleration Group	
		V/f Group	
	Torque Limit Group		
	<b>Operation Time</b>	Speed 1 Operation Time	F540
		Speed 2 Operation Time	F541
		Speed 3 Operation Time	F542
		Speed 4 Operation Time	F543
		Speed 5 Operation Time	F544
		Speed 6 Operation Time	F545
		Speed 7 Operation Time	F546
Speed 8 Operation Time		F547	
Speed 9 Operation Time		F548	

<b>Program Mode Menu Navigation</b>			
<b>Primary Menu</b>	<b>Sub Menu</b>	<b>Parameter Name</b>	<b>Parameter Number</b>
<b>PATTERN RUN</b>	<b>Operation Time</b>	Speed 10 Operation Time	F549
		Speed 11 Operation Time	F550
		Speed 12 Operation Time	F551
		Speed 13 Operation Time	F552
		Speed 14 Operation Time	F553
		Speed 15 Operation Time	F554
	<b>Pattern Run</b>	Pattern Operation	F520
		Pattern Operation Mode	F521
		Pattern 1 Repeat	F522
		Pattern 2 Repeat	F531
	<b>Speeds</b>	Pattern Group 1, Selection 1	F523
		Pattern Group 1, Selection 2	F524
		Pattern Group 1, Selection 3	F525
		Pattern Group 1, Selection 4	F526
		Pattern Group 1, Selection 5	F527
		Pattern Group 1, Selection 6	F528
		Pattern Group 1, Selection 7	F529
		Pattern Group 1, Selection 8	F530
		Pattern Group 2, Selection 1	F532
		Pattern Group 2, Selection 2	F533
		Pattern Group 2, Selection 3	F534
		Pattern Group 2, Selection 4	F535
		Pattern Group 2, Selection 5	F536
Pattern Group 2, Selection 6		F537	
Pattern Group 2, Selection 7		F538	
Pattern Group 2, Selection 8		F539	
<b>PASSWORD AND Lock Out</b>	<b>Enter Password</b>	Password is 0 (zero) for a new unit	N/A
	<b>Change Password</b>	Enter New Password	N/A



## Program Mode Menu Navigation

Primary Menu	Sub Menu	Parameter Name	Parameter Number
<b>PASSWORD AND Lock Out</b>	<b>Lock Outs</b>	Reset From Trip	N/A
		Hand/Auto	
		Run/Stop from EOI	
		Frequency Change From EOI	
		Monitor Screen	
		Parameter Access	
		Parameter Write	

# System Operation

## Operation (Hand)

*Note:* See the section titled [EOI Features on pg. 26](#) for information on **Auto** operation.

To turn the motor on, perform the following:

1. Connect the **CC** terminal to the **ST** terminal.
2. Press the **Mode** key until the **Frequency Command** screen is displayed.
3. Press the **Hand/Auto** key to enter the **Hand** mode (green **Hand** LED illuminates).
4. Turn the **Rotary Encoder** clockwise until the desired **Frequency Command** value is displayed in the **SET** field of the LCD screen.
5. Press the **Run** key and the motor runs at the **Frequency Command** value.

Frequency Command Screen

0		100%	
SET:	0.00 Hz		
DC Voltage:			0.00%
Output Current:			0.00%
F R ST RES S1 S2 S3 S4			
OUT1 OUT2 FL			

*Note:* The speed of the motor may be changed while the motor is running by using the **Rotary Encoder** to change the **Frequency Command** value.

6. Press the **Stop-Reset** key to stop the motor.

# Default Setting Changes

To change a default parameter setting, go to the root level of the **Program** menu. Turn the **Rotary Encoder** until the desired parameter group is within the cursor block. Press the **Rotary Encoder** to select an item or to access a subgroup (repeat if required until reaching the parameter to be changed).

Press the **Rotary Encoder** to enter the **Edit** mode and the value/setting takes on the reverse video format (dark background/light text). Turn the **Rotary Encoder** to change the parameter value/setting.

Press **ESC** key while the new parameter setting is still in the reverse video mode to exit the menu without saving the change or press the **Rotary Encoder** while the parameter setting is in the reverse video mode to accept the new setting.

For a complete listing of the **Program** mode menu selections, see the section titled **Program Mode Menu Navigation on pg. 34**. **Program** menu items are listed and mapped for convenience. The **Direct Access Numbers** are listed where applicable.

The default settings may also be changed by entering the **Parameter Number** of the setting to be changed at the **Direct Access** menu (Program ⇒ Direct Access ⇒ *Applicable Parameter Number*). A listing of the **Direct Access Numbers** and a description of the associated parameter may be found in the **P9 ASD Installation and Operation Manual**.

A listing of all parameters that have been changed from the default setting may be viewed sequentially by accessing the **Changed From Default** screen (Program ⇒ Utilities ⇒ **Changed From Default**).

The **Changed From Default** feature allows the user to quickly access the parameters that are different from the factory default settings or the post-Reset settings. Once the **Changed From Default** screen is displayed, the system scrolls through all of the system parameters automatically and halts once reaching a changed parameter.

Once stopped at a changed parameter, the **Rotary Encoder** may be clicked once clockwise to continue scrolling forward or clicked once counterclockwise to begin scrolling in reverse. With each click of the **Rotary Encoder** from a stop, the system scrolls through the parameters and stops at the next parameter that has been changed.

Press the **Rotary Encoder** while stopped at a changed parameter to display the settings of the changed parameter. Press the **Rotary Encoder** to enter the **Edit** mode — the parameter value/setting takes on the reverse video format (dark background/light text). Turn the **Rotary Encoder** to change the parameter setting.

Press the **ESC** key while the setting is in the reverse video format to exit the **Edit** mode without saving the change and to resume the **Changed From Default** search. Or press the **Rotary Encoder** while the setting is in the reverse video format to save the change. Press **ESC** to return to the **Changed From Default** search.

Pressing **ESC** while the system is performing a **Changed From Default** search terminates the search. Pressing **ESC** when finished searching (or halted at a changed parameter) takes the menu back one level.

**Note:** *Communications setting changes will require that the power be removed and then re-applied for the changes to take affect.*

**Note:** *Parameter F201 was changed to create the example shown in Figure 26.*

Figure 26. Changed From Default Screen.

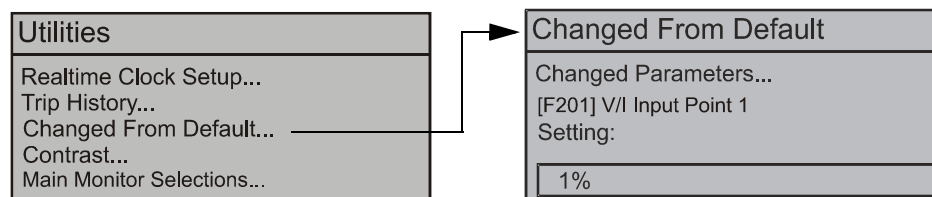

# Save User Settings

A profile of an existing setup may be saved and re-applied when required by using the **Save User Setup** feature. This function is carried out via Program ⇒ Utilities ⇒ Type Reset ⇒ **Save User Settings**.

With the initial setup saved, troubleshooting and diagnostics may be performed and the starting setup may be re-applied when finished via Program ⇒ Utilities ⇒ Type Reset ⇒ **Restore User Settings**.

**Note:** *EOI settings are not stored or restored using the **Save User Settings** or **Restore User Settings**, respectively (i.e., contrast setting, voltage/current units, display gradient characteristics, etc.). See the section titled [Battery Backup on pg. 24](#) for more information on stored EOI settings.*

# Virtual Linear Pump

Toshiba International Corporation's **Virtual Linear Pump (VLP)** algorithm allows for direct and precise control of pressure, flow rate, or level. This is achieved without the concerns, instabilities, or complexities that are traditionally associated with pumping system control.

This section provides useful setup and operational information of the **VLP** system.

The **VLP** system is initially configured using the **VLP Setup Wizard** selection via Program ⇒ Virtual Linear Pump ⇒ **VLP Setup Wizard**. Once the **VLP Setup Wizard** is started it must be completed for normal **VLP** operations to function.

However, the **VLP** parameters addressed while using the wizard or the **VLP Settings** menu selection are also accessible via their associated direct access numbers for specific adjustments when required.

The **VLP** setup procedure and the **VLP Setup Wizard** setup screens are shown below.

Figure 27. Input the Electrical Specifications of the Motor.

<ol style="list-style-type: none"> <li>From the nameplate of the motor, enter the FLA.</li> <li>Select <b>Pressure</b> or <b>Level</b>.</li> <li>Select the command source; <b>EOI</b> or <b>V/I</b> analog input.</li> <li>Set the <b>Low Frequency Limit</b>. 15 Hz fits most applications.</li> <li>Click <b>Next</b> to continue.</li> </ol>	<b>VLP Setup Wizard</b>		
	Back	Next	Exit
	Motor Full Load Amps		3.4A
	Application Type		Pressure
	Command Source		EOI
Low Frequency Limit		15.00Hz	

Figure 28. Input the Specifications of the Transducer.

<ol style="list-style-type: none"> <li>Set the unit of measure for the transducer; pressure, flow rate, or level (i.e., PSI, GPM, Inches of Water Column, Feet of Water Column, or Cubic Feet per Minute).</li> <li>Select the transducer output signal type; <b>Current</b> or <b>Voltage</b> and the range.</li> <li>Set the full-scale reading of the transducer.</li> <li>Click <b>Next</b> to continue.</li> </ol>	<b>VLP Setup Wizard</b>		
	Back	Next	Exit
	<b>Transducer</b>		
	Units		PSI
	Type		4-20 mA
Full Scale		0.0 PSI	

# ⚠ DANGER

## WARNING! — THE FOLLOWING STEP WILL START THE MOTOR!

Figure 29. The VLP Maximum Value.

<p>10. Set the system for normal flow and ensure that all system valves are set for normal operation.</p> <p>11. Place the system in the <b>Hand</b> mode and press the <b>Run</b> key.</p> <p>12. Click <b>Next</b> to continue.</p> <p style="padding-left: 20px;">The Motor/Pump combination capacity is automatically calculated and displayed as the <b>VLP Maximum</b>. Normally, no further adjustment is required for the <b>VLP Maximum</b> setting.</p> <p style="padding-left: 20px;">The <b>VLP Maximum</b> value may be adjusted, if required, at <b>F395</b>. The <b>VLP Maximum</b> setting (F395) minus the <b>F482</b> setting comprises the range of the <b>VLP Maximum Zone</b>.</p> <p>13. Click <b>Next</b> to continue.</p>	<table border="1" style="width: 100%; border-collapse: collapse; background-color: #f0f0f0;"> <tr> <th colspan="3" style="text-align: left; padding: 5px;">VLP Setup Wizard</th> </tr> <tr> <td style="padding: 5px;">Back</td> <td style="padding: 5px;">Next</td> <td style="padding: 5px;">Exit</td> </tr> <tr> <td colspan="3" style="padding: 5px;">Use Encoder To Set VLP</td> </tr> <tr> <td style="padding: 5px;"><b>Maximum</b></td> <td style="padding: 5px;"></td> <td style="padding: 5px; text-align: right;">80</td> </tr> <tr> <td style="padding: 5px;">Transducer Value</td> <td style="padding: 5px;"></td> <td style="padding: 5px; text-align: right;">12 %</td> </tr> </table>	VLP Setup Wizard			Back	Next	Exit	Use Encoder To Set VLP			<b>Maximum</b>		80	Transducer Value		12 %
VLP Setup Wizard																
Back	Next	Exit														
Use Encoder To Set VLP																
<b>Maximum</b>		80														
Transducer Value		12 %														

Figure 30. Set the VLP Minimum Value.

<p>14. The <b>VLP Minimum</b> value setting is typically above the electrical stall of the motor, above the minimum system pressure, above the manual change plateau, and well below the typical operating point of the system.</p> <p>Click in the <b>VLP Minimum</b> field and, using the <b>Rotary Encoder</b>, slowly decrease the <b>VLP Minimum</b> value while observing the LED display.</p> <p>If either of the conditions listed below should occur while decreasing the <b>VLP Minimum</b> value, increase the <b>VLP Minimum</b> number until the condition is no longer true to set the <b>VLP Minimum</b>:</p> <ul style="list-style-type: none"> <li>• The motor stalls,</li> <li>• The output frequency is greater than the setting of <b>F505</b>, or</li> <li>• The output frequency no longer changes with continued <b>VLP</b> number changes.</li> </ul> <p>The <b>VLP Minimum</b> setting (F394) plus the <b>F481</b> setting comprises the range of the <b>VLP Minimum Zone</b>.</p> <p>15. Click <b>Next</b> to continue.</p>	<table border="1" style="width: 100%; border-collapse: collapse; background-color: #f0f0f0;"> <tr> <th colspan="3" style="text-align: left; padding: 5px;">VLP Setup Wizard</th> </tr> <tr> <td style="padding: 5px;">Back</td> <td style="padding: 5px;">Next</td> <td style="padding: 5px;">Exit</td> </tr> <tr> <td colspan="3" style="padding: 5px;">Use Encoder To Set VLP</td> </tr> <tr> <td style="padding: 5px;"><b>Minimum</b></td> <td style="padding: 5px;"></td> <td style="padding: 5px; text-align: right;">70</td> </tr> <tr> <td style="padding: 5px;">Transducer Value</td> <td style="padding: 5px;"></td> <td style="padding: 5px; text-align: right;">12 %</td> </tr> </table>	VLP Setup Wizard			Back	Next	Exit	Use Encoder To Set VLP			<b>Minimum</b>		70	Transducer Value		12 %
VLP Setup Wizard																
Back	Next	Exit														
Use Encoder To Set VLP																
<b>Minimum</b>		70														
Transducer Value		12 %														

Figure 31. Complete the VLP Setup.

<p>16. Press the <b>Stop</b> key to complete the <b>VLP</b> setup.</p> <p>17. Click <b>Exit</b> to save settings (Exit available at zero Hz).</p>	<b>VLP Setup Wizard</b>		
	Back	Next	Exit
<p>Press [STOP] Virtual Linear Pump Setup Is Now Complete</p>			

Figure 32. Run the Motor/Pump in the Direct Mode.

<p>18. From the <b>Frequency Command</b> screen press <b>ESC</b>, scroll to the <b>VLP Control</b> field, and select <b>Direct Mode</b> if using no feedback (if using feedback go to <a href="#">Step 21. on pg. 65</a>).</p> <p>19. While in the <b>Hand</b> mode, and from the <b>Frequency Command</b> screen, press <b>Run</b>.</p> <p>20. During operation, adjust parameters <b>F500</b> and <b>F501</b> to stabilize <b>VLP</b> operation if unstable.</p>						
	<p>Press <b>ESC</b></p> <p>↓</p>					
	<table border="1"> <tr> <td colspan="2" style="text-align: center;"><b>Command</b></td> </tr> <tr> <td>Torque Limit Group</td> <td></td> </tr> <tr> <td>VLP Control</td> <td style="text-align: center;"><b>Direct Mode</b></td> </tr> </table>	<b>Command</b>		Torque Limit Group		VLP Control
<b>Command</b>						
Torque Limit Group						
VLP Control	<b>Direct Mode</b>					

Figure 33. Run the Motor/Pump in Process Hold Mode.

21. From the **Frequency Command** screen press **ESC**, scroll to the **VLP Control** field, and select **Process Hold** if using feedback (if not using feedback go to [Step 18. on pg. 64](#)).

22. From the **Frequency Command** screen press **Run**.

23. During operation, adjust parameters **F500** and **F501** to stabilize **VLP** operation if unstable.

0				100%
SET:	0.00 Hz			⊘
DC Voltage:				0.00%
Output Current:				0.00%
F R ST RES S1 S2 S3 S4 OUT1 OUT2 FL				

Press **ESC**

↓

**Command**

---

Torque Limit Group

VLP Control Process Hold



# Alarms, Trips, and Troubleshooting

## Alarms and Trips

This section lists the available user-notification codes of the EOI display and provides information that assists the user in the event that a **Fault** is incurred. The **User Notification** codes are displayed as an indication that a system function or system condition is active (i.e., ATN, DB, and DBON). The code is displayed on the EOI for the duration of the activation.

If a user setting or an P9 ASD parameter has been exceeded, or if a data transfer function produces an unexpected result, a condition that is referred to as a **Fault** is incurred.

An **Alarm** is an indication that a **Fault** is imminent if existing operating conditions continue unchanged. An **Alarm** may be associated with an output terminal to notify the operator of the condition remotely, close a contact, or engage a brake. At the least, an **Alarm** will cause an alarm code to appear on the EOI display. [Table 4](#) lists the **Alarm** codes that may be displayed during operation of the P9 ASD.

In the event that the condition that caused the **Alarm** does not return to its normal operating level within a specified time, the ASD **Faults** and a **Trip** is incurred (**Fault** and **Trip** are sometimes used interchangeably).

A **Trip** is a safety feature (the result of a **Fault**) that disables the P9 ASD system and removes the 3-phase power from the motor in the event that a subsystem of the ASD is malfunctioning, or one or more of the variables listed below exceeds its normal range (time and/or magnitude).

- Current,
- Voltage,
- Speed,
- Temperature,
- Torque, or
- Load.

See [Table 5 on pg. 70](#) for a listing of the potential **Trips** and the associated probable causes.

The operating conditions at the time of the trip may be used to help determine the cause of the trip. Listed below are operating conditions that may be used to assist the operator in correcting the problem or that the P9 ASD operator should be prepared to discuss when contacting the TIC Customer Support Center for assistance.

- What trip information is displayed?
- Is this a new installation?
- Has the system ever worked properly and what are the recent modifications (if any)?
- What is the ASD and Motor size?
- What is the CPU version and revision level?
- What is the EOI version?
- Does the ASD trip when accelerating, running, decelerating, or when not running?
- Does the ASD reach the commanded frequency?
- Does the ASD trip without the motor attached?
- Does the ASD trip with an unloaded motor?

# User Notification Codes

The **User Notification** codes appear in the top right corner of the **Frequency Command** screen while the associated function is active.

**User Notification** codes notify the user of active functions that are usually only momentary under normal conditions and are active for the duration of activation only. User notification events are not error conditions and only convey active system functions to the user.

Table 3. User Notification Codes.

<b>LED</b>	<b>Function</b>	<b>Description</b>
<b>Atn</b>	Autotune active	<b>Atn</b> indicates that the <b>Autotune</b> function is active.
<b>dbOn</b>	DC Braking	This code conveys the <b>DC Injection</b> function being carried out. The display shows <b>db</b> when braking and shows <b>dbOn</b> when the motor shaft stationary function is being carried out.

# Alarms

Table 4 lists the alarm codes that may be displayed during operation of the P9 ASD. Each alarm code listed is accompanied by a description and a possible cause. In the event that the source of the malfunction cannot be determined, contact your TIC Sales Representative for further information on the condition and for an appropriate course of action.

The **Alarms** are listed in the top-down order that they are checked for activation. Only the first to be detected will be displayed on the **Frequency Command** screen.

Table 4. P9 ASD Alarms.

LED Screen	LCD Screen	Description	Possible Causes/Troubleshooting
CM1	Comm1 Error	Internal communications error.	<ul style="list-style-type: none"> <li>Improperly programmed ASD.</li> <li>Improper communications settings.</li> <li>Improperly connected cables.</li> </ul>
CM2	Comm2 Error	External communications error.	
E	Emergency Off	Output signal from the ASD is terminated and a brake may be applied if so configured.	<ul style="list-style-type: none"> <li>Stop/Reset pressed twice at the EOI.</li> <li>EOFF command received remotely.</li> <li>ASD reset required.</li> </ul>
MOFF	Main Under-Voltage	Under-voltage condition at the 3-phase AC input to the ASD.	<ul style="list-style-type: none"> <li>Low 3-phase commercial voltage.</li> </ul>
OC	Over-Current	ASD output current greater than F601 setting.	<ul style="list-style-type: none"> <li>Defective IGBT (U, V, or W).</li> <li>ASD output to the motor is connected incorrectly.</li> <li>ASD output phase-to-phase short.</li> <li>The ASD is starting into a spinning motor.</li> <li>Motor/machine jammed.</li> <li>Mechanical brake engaged while the ASD is starting or while running.</li> <li>Accel/Decel time is too short.</li> <li>Voltage Boost setting is too high.</li> <li>Load fluctuations.</li> <li>ASD operating at an elevated temperature.</li> </ul>
*OH	Overheat	ASD ambient temperature excessive.	<ul style="list-style-type: none"> <li>ASD is operating at an elevated temperature.</li> <li>ASD is too close to heat-generating equipment.</li> <li>Cooling fan vent is obstructed (see <a href="#">Mounting the ASD on pg. 11</a>).</li> <li>Cooling fan is inoperative.</li> <li>Internal thermistor is disconnected.</li> </ul>
OJ	Timer	Run-time counter exceeded.	<ul style="list-style-type: none"> <li><b>Type Reset</b> required; select <b>Clear run timer</b>.</li> </ul>
* Reset ignored if active.			

LED Screen	LCD Screen	Description	Possible Causes/Troubleshooting
*OLI	ASD Overload	Load requirement in excess of the capability of the ASD.	<ul style="list-style-type: none"> <li>The carrier frequency is too high.</li> <li>An excessive load.</li> <li>Acceleration time is too short.</li> <li>DC damping rate is set too high.</li> <li>The motor is starting into a spinning load after a momentary power failure.</li> <li>The ASD is improperly matched to the application.</li> </ul>
OLM	Motor Overload	Load requirement in excess of the capability of the motor.	<ul style="list-style-type: none"> <li>V/f parameter improperly set.</li> <li>Motor is locked.</li> <li>Continuous operation at low speed.</li> <li>The load is in excess of what the motor can deliver.</li> </ul>
*OLR	Resistor Overload	Excessive current at the <b>Dynamic Braking Resistor</b> .	<ul style="list-style-type: none"> <li>Deceleration time is too short.</li> <li>DBR configuration improperly set.</li> </ul>
*OP	Over-Voltage	DC bus voltage exceeds specifications.	<ul style="list-style-type: none"> <li>ASD attempting to start into a spinning motor after a momentary power loss.</li> <li>Incoming commercial power is above the specified range.</li> <li>Decel time is too short.</li> <li>Voltage spikes at the 3-phase input; install inductive filter.</li> <li>DBR required.</li> <li>DBR resistance value is too high.</li> <li>DBR function is turned off.</li> <li>Over-Voltage Stall feature is turned off.</li> <li>System is regenerating.</li> <li>Load instability.</li> <li>Disable the Ridethrough function (F302).</li> </ul>
OT	Over-Torque	Torque requirement is in excess of the setting of <b>F616</b> or <b>F617</b> for a time longer than the setting of <b>F618</b> .	<ul style="list-style-type: none"> <li>ASD is not correctly matched to the application.</li> <li><b>F616</b> or <b>F617</b> setting is too low.</li> <li>Obstructed load.</li> </ul>
*POFF	Control Under-Voltage	Under-voltage condition at the 5, 15, or the 24 VDC supply.	<ul style="list-style-type: none"> <li>Defective Control board.</li> <li>Excessive load on power supply.</li> <li>Low input voltage.</li> </ul>
PtSt	Reference Point	Two speed-reference frequency setpoint values are too close to each other.	<ul style="list-style-type: none"> <li>Two speed reference frequency setpoints are too close to each other (increase the difference).</li> </ul>
UC	Under-Current	With the <b>Low-Current Trip</b> (F610) parameter enabled, the output current of the ASD is below the level defined at <b>F611</b> and remains there for a time longer than the setting of <b>F612</b> .	<ul style="list-style-type: none"> <li>Output current too low.</li> </ul>
* Reset ignored if active.			

# Trips/Faults

A **Trip** is an P9 ASD response to a **Fault** (though **Fault** and **Trip** are sometimes used interchangeably). A **Trip** is a safety feature that disables the ASD system in the event that a subsystem of the ASD is malfunctioning or a parameter setting has been exceeded.

Listed in [Table 5](#) are the **Faults** that may result in a **Trip** and the possible causes. When a **Trip** is incurred the system displays the **Fault** screen. The **Fault** screen identifies the active **Fault**.

Table 5. P9 ASD Fault Listing.

LED Screen	LCD Screen	Possible Causes/Troubleshooting
<b>AbFL</b>	Low Suction/No Flow Cut Off	<ul style="list-style-type: none"> <li>Loss of suction pressure or closed pump output valve.</li> <li>Activated discrete input terminal set to <b>Low Suction/No Flow Protection</b>.</li> <li>ASD <a href="#">Upper-Limit Frequency</a> run-time is equal to <b>F484</b> time setting.</li> </ul>
<b>E</b>	Emergency Off	<ul style="list-style-type: none"> <li>Emergency Off command received via EOI or remotely.</li> </ul>
<b>E-10</b>	Sink/Source Setting Error	<ul style="list-style-type: none"> <li>Improperly positioned <b>Sink/Source</b> jumper on the Terminal board or on an option device (see J100 at the Terminal PCB of the ASD).</li> <li><b>Sink/Source</b> configuration is incorrect.</li> </ul>
<b>E-11</b>	Brake Sequence Response Error	<ul style="list-style-type: none"> <li><b>F630</b> is set to a non-zero value.</li> <li>Braking sequence discrete input and output terminals are not set up properly.</li> </ul>
<b>E-12</b>	Encoder Signal-Loss Error	<ul style="list-style-type: none"> <li>ASD is configured to receive a signal from a shaft-mounted encoder and no signal is being received while running.</li> <li>Disconnection at the Encoder circuit.</li> <li>Motor is stopped and is generating torque via torque limit control.</li> <li>ASD is not configured properly.</li> </ul>
<b>E-13</b>	Speed Error	<ul style="list-style-type: none"> <li>Result of a motor speed that is greater than the commanded speed when using an encoder for speed control.</li> <li>Improper encoder connection or setup information.</li> <li>Defective encoder.</li> </ul>
<b>E-17</b>	Key Failure	<ul style="list-style-type: none"> <li>Same key input for 20 seconds or more.</li> </ul>
<b>E-18</b>	Analog (Terminal) Input Loss	<ul style="list-style-type: none"> <li>V/I signal loss.</li> <li>Terminal Board failure.</li> <li>P24 over-current condition.</li> <li><b>F633</b> setting is too high.</li> </ul>
<b>E-19</b>	CPU Communication Error	<ul style="list-style-type: none"> <li>CPU data Transmit/Receive error.</li> </ul>
<b>E-20</b>	V/f Control Error	<ul style="list-style-type: none"> <li>Torque processing error.</li> <li>Make service call.</li> </ul>
<b>E-21</b>	CPU Processing Error	<ul style="list-style-type: none"> <li>Software processed incorrectly.</li> <li>Make service call.</li> </ul>
<b>E-22</b>	Logic Input Voltage Error	<ul style="list-style-type: none"> <li>Incorrect voltage applied to the discrete input terminals.</li> </ul>

LED Screen	LCD Screen	Possible Causes/Troubleshooting
E-23	Optional Expansion Input Terminal Board 1 Error	<ul style="list-style-type: none"> <li>Optional Expansion Input Terminal Board 1 is defective.</li> </ul>
E-24	Optional Expansion Input Terminal Board 2 Error	<ul style="list-style-type: none"> <li>Optional Expansion Input Terminal Board 2 is defective.</li> </ul>
E-25	Stop Positioning Retention Error	<ul style="list-style-type: none"> <li>Load movement while stopped.</li> <li><b>F381</b> setting is too low.</li> <li>Encoder malfunction.</li> <li>Creep speed is too high.</li> </ul>
E-26	CPU2 Fault	<ul style="list-style-type: none"> <li>CPU malfunction.</li> <li>Control board malfunction.</li> </ul>
E-50/E-51	Sink/Source Setting Error	<ul style="list-style-type: none"> <li>Improperly positioned <b>Sink/Source</b> jumper on the Terminal board or on an option device (see J100 at the Terminal PCB of the ASD).</li> <li><b>Sink/Source</b> configuration is incorrect.</li> </ul>
EEP1	EEPROM Fault	<ul style="list-style-type: none"> <li>EEPROM write malfunction.</li> <li>Make a service call.</li> </ul>
EEP2/EEP3	EEPROM Read Error	<ul style="list-style-type: none"> <li>EEPROM read malfunction.</li> <li>Make a service call.</li> </ul>
EF1/EF2	(Earth) Ground Fault	<ul style="list-style-type: none"> <li>Ground fault at the motor.</li> <li>Ground fault at the output of the ASD.</li> <li>Current leakage to <b>Earth Ground</b>.</li> </ul>
EPHI	Input Phase Failure	<ul style="list-style-type: none"> <li>3-phase input to the ASD is low or missing at the R, S, or T input terminals.</li> </ul>
EPHO	Output Phase Failure	<ul style="list-style-type: none"> <li>3-phase output from the ASD is low or missing at the U, V, or W output terminals or at the input to the motor.</li> </ul>
ERR2	RAM Fault	<ul style="list-style-type: none"> <li>Internal RAM malfunction.</li> <li>Make a service call.</li> </ul>
ERR3	ROM Fault	<ul style="list-style-type: none"> <li>Internal ROM malfunction.</li> <li>Make a service call.</li> </ul>
ERR4	CPU Fault	<ul style="list-style-type: none"> <li>CPU malfunction.</li> <li>Control board malfunction.</li> <li>Make a service call.</li> </ul>
ERR5	Communication Error	<ul style="list-style-type: none"> <li>Communication time out error.</li> <li>Communication malfunction.</li> <li>Improper or loose connection.</li> <li>Improper system settings.</li> </ul>
ERR6	Gate Array Fault	<ul style="list-style-type: none"> <li>Main Gate Array is defective.</li> </ul>
ERR7	Low -Current	<ul style="list-style-type: none"> <li>Improper Low- Current detection level settings at <b>F609 – F612</b>.</li> </ul>
ERR8	Option Device Fault	<ul style="list-style-type: none"> <li>Check installation, connections, and option device manual.</li> </ul>

LED Screen	LCD Screen	Possible Causes/Troubleshooting
<b>ERR9</b>	Flash Memory Fault	<ul style="list-style-type: none"> <li>Flash memory malfunction.</li> <li>Make a service call.</li> </ul>
<b>ETN</b>	Autotune Error	<ul style="list-style-type: none"> <li><b>Autotune</b> readings that are significantly inconsistent with the configuration information.</li> <li>A non-3-phase motor is being used.</li> <li>Incorrect settings at <b>F400</b> or <b>F413</b>.</li> <li>Using a motor that has a significantly smaller rating than the ASD.</li> <li>ASD output cabling is too small, too long, or is being housed in a cable tray with other cables that are producing an interfering EMF.</li> <li>Motor is running during the <b>Autotune</b> function.</li> </ul>
<b>ETN1</b>		<ul style="list-style-type: none"> <li><b>F402</b> adjustment required (Motor temperature is too high).</li> <li><b>F410</b> adjustment required (Motor Constant 1 improperly set).</li> </ul>
<b>ETN2</b>		<ul style="list-style-type: none"> <li><b>F412</b> adjustment required (Motor Constant 3 improperly set).</li> </ul>
<b>ETN3</b>		<ul style="list-style-type: none"> <li>Autotune setting <b>F400</b> is set to Auto Calculation and there is a problem with the Motor Constant readings.</li> </ul>
<b>ETYP</b>	Typeform Error	<ul style="list-style-type: none"> <li>Firmware information (typeform) loaded into the <b>Gate Driver</b> board is inconsistent with the device in which the firmware is being used.</li> <li>The <b>Gate Driver</b> board has been replaced.</li> <li>The <b>Gate Driver</b> board is defective.</li> </ul>
<b>None</b>	No Errors	<ul style="list-style-type: none"> <li>No active faults.</li> </ul>
<b>OC1</b>	Over-Current During Acceleration	<ul style="list-style-type: none"> <li>Improper V/f setting.</li> <li>Restart from a momentary power outage.</li> <li>The ASD is starting into a rotating motor.</li> <li>ASD/Motor not properly matched.</li> <li>Phase-to-phase short (<b>U</b>, <b>V</b>, or <b>W</b>).</li> <li><b>Accel</b> time too short.</li> <li><b>Voltage Boost</b> setting is too high.</li> <li>Motor/machine jammed.</li> <li>Mechanical brake engaged while the ASD is running.</li> <li>ASD current exceeds 340% of the rated FLA on ASDs that are 100 HP or less during acceleration. On ASDs that are greater than 100 HP, this fault occurs when the ASD current exceeds 320% of the rated FLA during acceleration.</li> </ul>
<b>OC1P</b>	Overheat During Acceleration	<ul style="list-style-type: none"> <li>Cooling fan inoperative.</li> <li>Ventilation openings are obstructed.</li> <li>Internal thermistor is disconnected.</li> <li>Acceleration time is too short.</li> <li>Improper V/f setting.</li> <li>ASD or the motor is improperly matched to the application.</li> </ul>

LED Screen	LCD Screen	Possible Causes/Troubleshooting
<b>OC2</b>	Over-Current During Deceleration	<ul style="list-style-type: none"> <li>Phase-to-phase short (U, V, or W).</li> <li>Deceleration time is too short.</li> <li>Motor/machine jammed.</li> <li>Mechanical brake engaged while the ASD is running.</li> <li>ASD current exceeds 340% of the rated FLA on ASDs that are 100 HP or less during deceleration. On ASDs that are greater than 100 HP, it occurs when the ASD current exceeds 320% of the rated FLA during deceleration.</li> </ul>
<b>OC2P</b>	Overheat During Deceleration	<ul style="list-style-type: none"> <li>Cooling fan inoperative.</li> <li>Ventilation openings are obstructed.</li> <li>Internal thermistor is disconnected.</li> <li>Deceleration time is too short.</li> <li>DC Injection current is too high.</li> <li>ASD or the motor is improperly matched to the application.</li> </ul>
<b>OC3</b>	Over-Current During Run	<ul style="list-style-type: none"> <li>Load fluctuations.</li> <li>ASD is operating at an elevated temperature.</li> <li>ASD current exceeds 340% of the rated FLA on ASDs that are 100 HP or less during a fixed-speed run or if during a fixed-speed run the ASD overheats. On ASDs that are greater than 100 HP, it occurs when the ASD current exceeds 320% of the rated FLA on a fixed-speed run.</li> </ul>
<b>OC3P</b>	Overheat During Run	<ul style="list-style-type: none"> <li>Cooling fan inoperative.</li> <li>Ventilation openings are obstructed.</li> <li>Internal thermistor is disconnected.</li> <li>Improper V/f setting.</li> <li>ASD or the motor is improperly matched to the application.</li> </ul>
<b>OCA1 or OCL</b>	U-Phase Over-Current	<ul style="list-style-type: none"> <li>Low impedance at the U lead of the ASD output.</li> </ul>
<b>OCA2 or OCL</b>	V-Phase Over-Current	<ul style="list-style-type: none"> <li>Low impedance at the V lead of the ASD output.</li> </ul>
<b>OCA3 or OCL</b>	W-Phase Over-Current	<ul style="list-style-type: none"> <li>Low impedance at the W lead of the ASD output.</li> </ul>
<b>OCR</b>	Dynamic Braking Resistor Over-Current	<ul style="list-style-type: none"> <li>ASD inability to discharge the bus voltage during regeneration.</li> <li>No dynamic braking resistor (DBR) installed.</li> <li>Deceleration time is too short.</li> <li>Improper DBR setup information.</li> <li>Defective IGBT7 (or IGBT7 ckt.).</li> <li>3-phase input voltage is above specification.</li> </ul>
<b>OH</b>	Overheat	<ul style="list-style-type: none"> <li>Cooling fan inoperative.</li> <li>Ventilation openings are obstructed.</li> <li>Internal thermistor is disconnected.</li> </ul>
<b>OH2</b>	External Overheat	<ul style="list-style-type: none"> <li>Excessive-heat signature received at the <b>TB3 – TH1(+)</b> and <b>TH1(-)</b> terminals. See <b>F637</b> for setup information.</li> </ul>



LED Screen	LCD Screen	Possible Causes/Troubleshooting
<b>OL1</b>	ASD Overload	<ul style="list-style-type: none"> <li>• Acceleration time is too short.</li> <li>• DC Injection current is too high.</li> <li>• Improper V/f setting.</li> <li>• Motor running during restart.</li> <li>• ASD or the motor is improperly matched to the application.</li> </ul>
<b>OL2</b>	Motor Overload	<ul style="list-style-type: none"> <li>• Improper V/f setting.</li> <li>• Motor is locked.</li> <li>• Continuous operation at low speed.</li> <li>• Load requirement exceeds ability of the motor.</li> <li>• Startup frequency setting adjustment required.</li> </ul>
<b>OLR</b>	Dynamic Braking Resistor Overload	<ul style="list-style-type: none"> <li>• Deceleration time is too short.</li> <li>• DBR setting adjustment required.</li> <li>• Over-Voltage Stall setting adjustment required.</li> </ul>
<b>OP1</b>	Over-Voltage During Acceleration	<ul style="list-style-type: none"> <li>• Motor running during restart.</li> </ul>
<b>OP2</b>	Over-Voltage During Deceleration	<ul style="list-style-type: none"> <li>• Deceleration time is too short.</li> <li>• DBR value is too high.</li> <li>• DBR required (DBR setup required).</li> <li>• Stall protection is disabled.</li> <li>• 3-phase input voltage is out of specification.</li> <li>• Input reactance required.</li> </ul>
<b>OP3</b>	Over-Voltage During Run	<ul style="list-style-type: none"> <li>• Load fluctuations.</li> <li>• 3-Phase input voltage out of specification.</li> <li>• DBR required (DBR setup required).</li> </ul>
<b>OT</b>	Over-Torque	<ul style="list-style-type: none"> <li>• A torque requirement by the load in excess of the setting of <b>F616</b> or <b>F617</b> for a time longer than the setting of <b>F618</b>.</li> <li>• The ASD is improperly matched to the application.</li> <li>• The load is obstructed.</li> </ul>
<b>SEAL</b>	Sealing Water Error	<ul style="list-style-type: none"> <li>• Inadequate pump seal water.</li> <li>• Loss of pump seal water.</li> </ul>
<b>SOUT</b>	Step-Out (for PM Motor Only)	<ul style="list-style-type: none"> <li>• Motor shaft is locked.</li> <li>• Output phase is open.</li> <li>• Operating a reciprocating load.</li> </ul>
<b>UP1</b>	Main Power Under-Voltage	<ul style="list-style-type: none"> <li>• Input 3-phase voltage is too low.</li> <li>• Momentary power failure longer than the time setting of <b>F628</b>.</li> </ul>
<b>UP2</b>	Control Power Under-Voltage	<ul style="list-style-type: none"> <li>• This fault is caused by an under-voltage condition at the 5, 15, or the 24 VDC supply.</li> <li>• 3-phase input voltage low.</li> </ul>

# Viewing Trip Information

In the event that the condition causing an **Alarm** does not return to the normal operating level within a specified time, the P9 ASD **Faults** and a **Trip** is incurred.

When a trip occurs, the resultant error information may be viewed either from the LED screen, LCD **Fault** screen (Table 5 on pg. 70), **Monitor** screen, or the **Trip History** screen (Program ⇒ Utilities ⇒ **Trip History**).

## Trip Record at Monitor Screen

The at-trip condition of the last 4 incurred trips may be viewed at the **Monitor** screen. The **Monitor** screen displays the records of up to four trips and catalogs each trip as **Past Trip 1** through **Past Trip 4** (see pg. 32). Once reset (**Type Reset**), the trip records are erased. If no trips have occurred since being powered up or since the last reset, **None** is displayed for each trip record.

The **Monitor** screen at-trip record is erased when the P9 ASD is reset.

*Note:* An improper P9 ASD setup may cause some trips — reset the ASD to the **Factory Default** settings before pursuing a systemic malfunction (Program ⇒ Utilities ⇒ Type Reset ⇒ **Reset to Factory Settings**).

## Trip History

The **Trip History** screen records the system parameters for up to 20 trips. The recorded trips are numbered from zero to 19. Once the **Trip History** record reaches trip number 19, the oldest recorded trip will be deleted with each new record stored (first-in first-out). The **Trip #** field may be selected and scrolled through to view the recorded trip information for a given trip number. The monitored parameters are listed in Table 6 as **At-trip Recorded Parameters** (parameter readings at the time that the trip occurred).

In the event of a power loss or if the keypad has been removed from the ASD, the trip records and the real-time clock information are retained within the keypad for up to 4.5 years via **Battery Backup**.

Table 6. Trip History Record Parameters.

At-trip Recorded Parameters			
1) Trip Number	8) Frequency Reference	15) Feedback (1 sec.)	22) ASD Overload
2) Trip Type	9) Bus Voltage	16) Torque	23) DBR Overload
3) Time and Date	10) Discrete Input Status	17) Torque Reference	24) Motor Load
4) Frequency at Trip	11) OUT1/OUT2/FL Status	18) Torque Current	25) ASD Load
5) Output Current	12) Timer	19) Excitation Current	26) DBR Load
6) Output Voltage	13) Post Compensation Frequency	20) PID Value	27) Input Power
7) Direction	14) Feedback (inst.)	21) Motor Overload	28) Output Power
Trip records are comprised of the full list of monitored parameters (28).			

## Clearing a Trip

Once the cause of the trip has been corrected, performing a **Reset** re-enables the P9 ASD for normal operation.

The record of a trip may also be cleared using either of the following methods:

- Cycling power (trip info may be saved via **F602** if desired),
- Pressing the **Stop-Reset** key twice,
- Remotely via the communications channel,
- Momentarily connecting terminal **RES** to **CC** of the **Terminal Board**, or
- Via Program ⇒ Utilities ⇒ Type Reset ⇒ **Clear Past Trip** (clears Monitor screen records only).

# Enclosure and Conduit Plate Dimensions

The P9 ASD part numbering convention is shown below.

The enclosure dimensions for the available models (typeforms) are listed in [Tables 7 and 8](#). The conduit plates referenced are shown in [Figures 37, 38, and 39](#).

## P9 Part Numbering Convention.

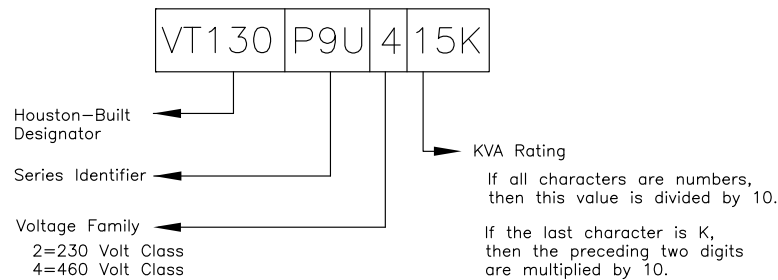

**Note:** The Type 1 enclosed versions of these drives meet or exceed the specification **UL 50-1995, the Standard for Heating and Cooling Equipment**, and complies with the applicable requirements for installation in a compartment handling conditioned air.

## Enclosure Dimensions

Table 7. 230-Volt P9 ASD Systems.

Frame	Model Number VT130P9U	Enclosure Figure Number	A Width (in/mm)	B Height (in/mm)	C Depth (in/mm)	Mounting Hole Dimensions (in/mm)				Conduit Plate		
						D	E	R1	R2			
2	2010	Figure 34	5.2/132	11.2/285	6.1/155	8.7/220	4.5/114	0.098/2.5	0.217/5.5	Figure 37-A		
	2015											
	2025											
3	2035		6.1/155	12.4/315	6.6/168	9.8/249	5.4/138	0.236/6.0	Figure 37-B			
	2055											
4	2080		6.9/175	15.0/381	11.1/283	6.2/158	0.118/3.0	0.276/7.0	Figure 37-D			
	2110											
5B	2160		9.1/231	19.3/490	7.6/193	15.2/386	8.3/210	0.188/4.8	0.375/9.5		Figure 38-G	
	2220											
	2270											
6	2330	Figure 35	11.1/283	25.9/658	13.2/335	25.0/635	8.0/203	0.344/8.7	0.670/17	Figure 37-E		
7B	2400		14.3/363	33.1/841	15.0/381	32.3/820				9.2/234	0.344/8.7	0.670/17
	2500											
	2600											
	2750											
9	210K	Figure 36	14.6/371	51.7/1313	17.6/447	50.2/1275	9.2/234	0.344/8.7	0.670/17	Figure 38-I		
10	212K		15.7/399	53.1/1349		51.7/1313	9.9/252			Figure 38-J		

Table 8. 460-Volt P9 ASD Systems.

Frame	Model Number VT130P9U	Enclosure Figure Number	A Width (in/mm)	B Height (in/mm)	C Depth (in/mm)	Mounting Hole Dimensions (in/mm)				Conduit Plate
						D	E	R1	R2	
2	4015	Figure 34	5.2/132	11.2/285	6.1/155	8.7/220	4.5/114	0.098/2.5	0.217/5.5	Figure 37-A
	4025									
	4035									
3	4055		6.1/155	12.4/315	6.6/168	9.8/249	5.4/138	0.118/3.0	0.276/7.0	Figure 37-B
	4080									
4	4110		6.9/175	15.0/381	7.6/193	11.1/283	6.2/158	0.118/3.0	0.276/7.0	Figure 37-C
5A	4160		8.3/211	15.1/384						
	4220		9.1/231	19.3/490						
5B	4270									
	4330									
6	4400	Figure 35	11.1/283	25.9/658	13.2/335	25.0/635	8.0/203	0.188/4.8	0.375/9.5	Figure 37-E
7A	4500			30.8/782	14.3/363	29.7/754				Figure 37-F
	4600		14.3/363	36.1/917	15.3/389	35.3/897				
8	4750									
	410K									
	412K									
9	415K	Figure 36	14.6/371	51.7/1313	17.6/447	50.2/1275	9.2/234	0.344/8.7	0.670/17	Figure 38-I
10	420K		15.7/399	53.1/1349		51.7/1313	9.9/252			Figure 38-J
11	425K		15.0/381	63.1/1603		61.6/1565				Figure 38-K
12	430K		18.9/480	68.5/1740		67.0/1701	13.8/351			Figure 39-L
	435K		25.6/650	70.0/1778		68.5/1740	21.3/541			Figure 39-M
13	440K									

Figure 34. See [Tables 7](#) and [8](#) for Actual Dimensions.

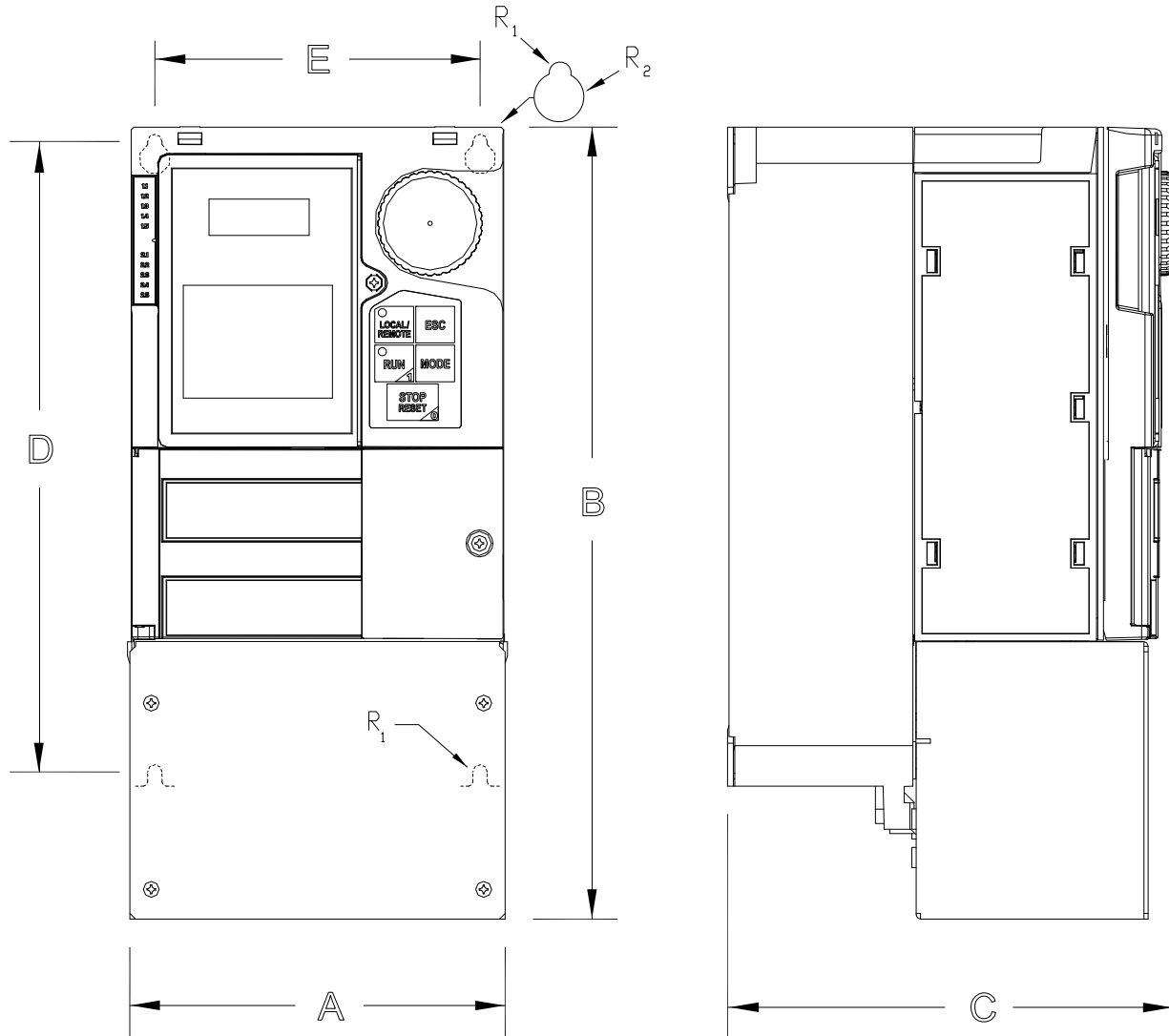

Figure 35. See [Tables 7](#) and [8](#) for Actual Dimensions.

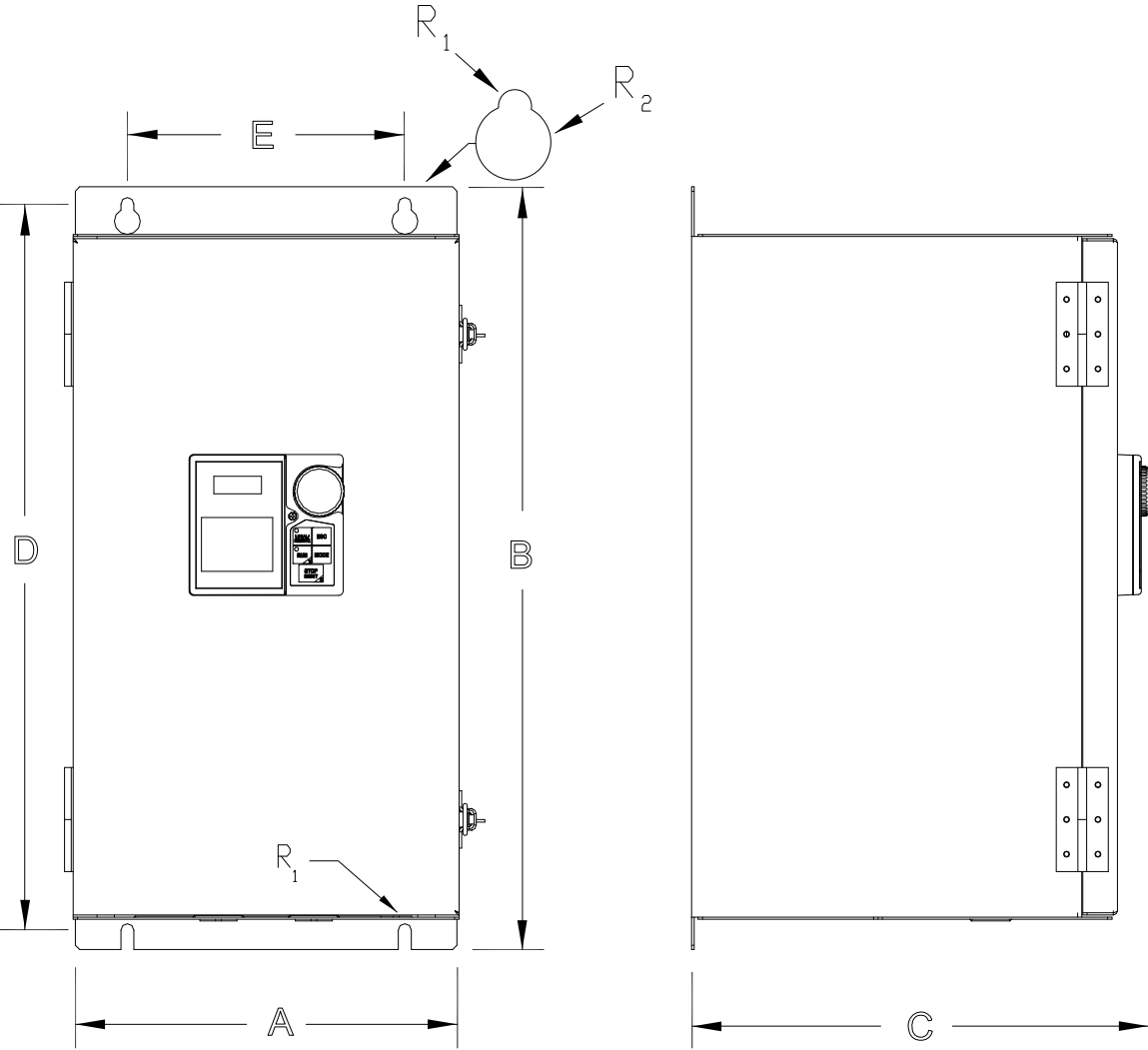
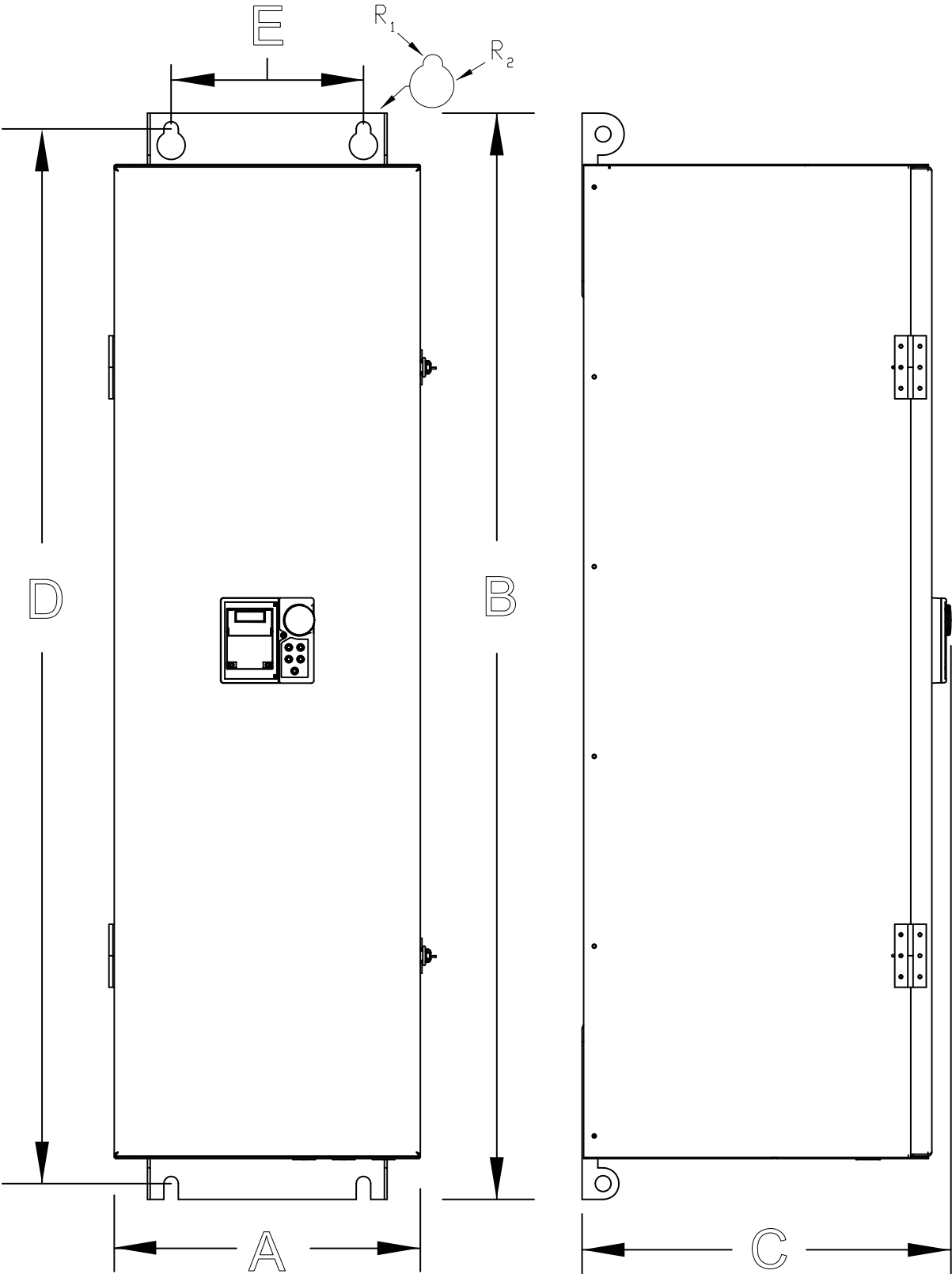

Figure 36. See [Tables 7](#) and [8](#) for Actual Dimensions.



# Conduit Plate Dimensions

Figure 37. See [Tables 7](#) and [8](#) for the associated device. Dimensions are in in/cm.

ØX = Concentric Knockouts for Diameter Sizes 0.5", 0.75", and 1.0" Conduit.

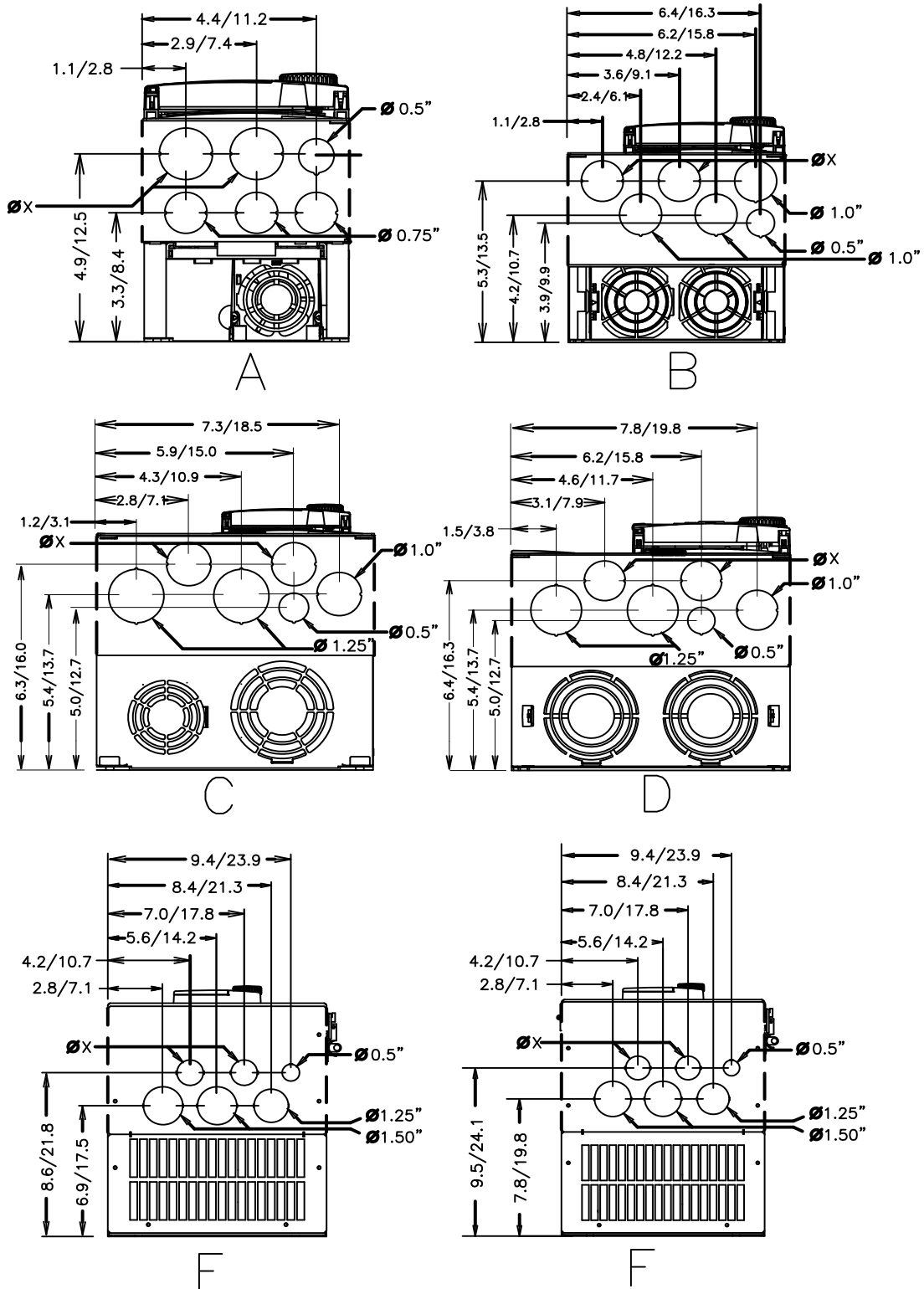
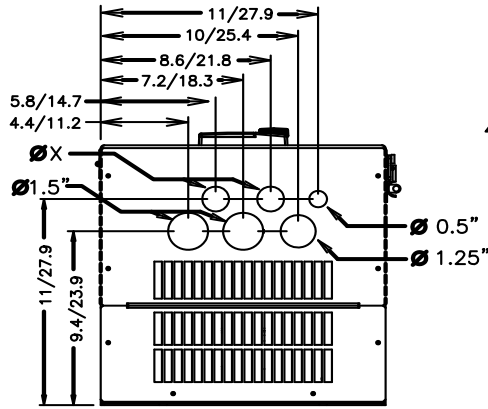

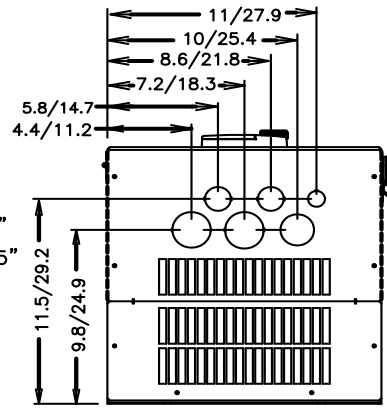

Figure 38. See [Tables 7](#) and [8](#) for the associated device. Dimensions are in in/cm.

ØX = Concentric Knockouts for Diameter Sizes 0.5", 0.75", and 1.0" Conduit.



G



Conduit Ø = Same as G

H

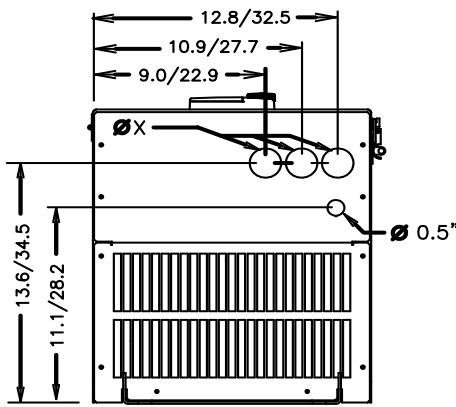

I

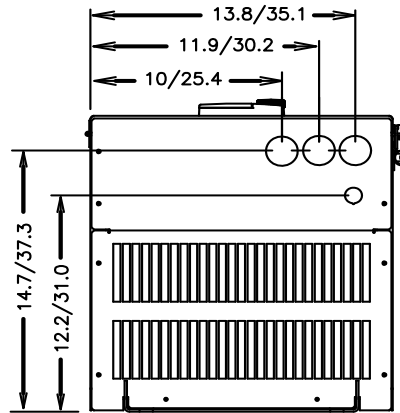

Conduit Ø = Same as I

J

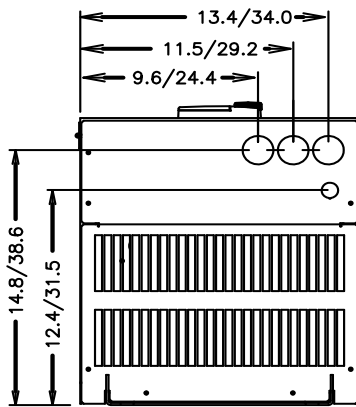

Conduit Ø = Same as I

K

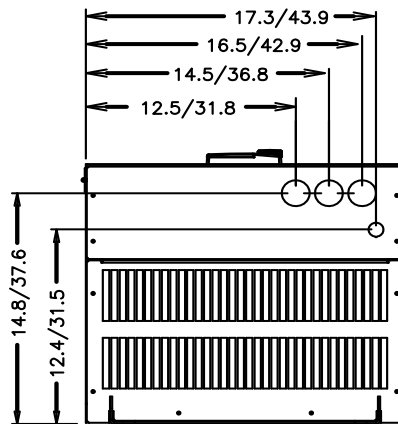

Conduit Ø = Same as I

L

Figure 39. See [Table 8](#) for the associated device. Dimensions are in in/cm.

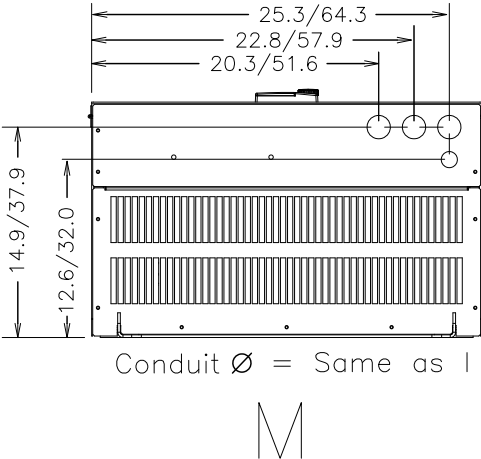

# Current/Voltage Specifications

Table 9. 230-Volt Chassis Standard Ratings Table.

Model Number VT130P9U	Typical Motor HP	100% Output Current Continuous	Overload Current 120% for 60 Seconds	Input Voltage 3-Ph 50/60 ±2 Hz	Output Voltage 3-Ph Variable Frequency
2010	0.75	3.2 A	3.84 A	200 – 240 VAC (±10%)	Input Voltage Level (Max.)
2015	1.0	4.2 A	5.04 A		
2025	2.0	6.8 A	8.16 A		
2035	3.0	9.6 A	11.5 A		
2055	5.0	15.2 A	18.2 A		
2080	7.5	22.0 A	26.0 A		
2110	10	28.0 A	34.0 A		
2160	15	42.0 A	50.0 A		
2220	20	54.0 A	65.0 A		
2270	25	68.0 A	82.0 A		
2330	30	80.0 A	96.0 A		
2400	40	104 A	125 A		
2500	50	130 A	156 A		
2600	60	154 A	185 A		
2750	75	192 A	230 A		
210K	100	248 A	298 A		
212K	125	312 A	374 A		

Table 10. 460-Volt Chassis Standard Ratings Table.

Model Number VT130P9U	Typical Motor HP	100% Output Current Continuous	Overload Current 120% for 60 Seconds	Input Voltage 3-Ph 50/60 ±2 Hz	Output Voltage 3-Ph Variable Frequency
4015	1.0	2.1 A	2.52 A	380 – 480 VAC (±10%)	Input Voltage Level (Max.)
4025	2.0	3.4 A	4.08 A		
4035	3.0	4.8 A	5.76 A		
4055	5.0	7.6 A	9.00 A		
4080	7.5	11.0 A	13.0 A		
4110	10	14.0 A	17.0 A		
4160	15	21.0 A	25.0 A		
4220	20	27.0 A	32.0 A		
4270	25	34.0 A	41.0 A		
4330	30	40.0 A	48.0 A		
4400	40	52.0 A	62.0 A		
4500	50	65.0 A	78.0 A		
4600	60	77.0 A	92.0 A		
4750	75	96.0 A	115 A		
410K	100	124 A	149 A		
412K	125	156 A	187 A		
415K	150	180 A	216 A		
420K	200	240 A	288 A		
425K	250	302 A	362 A		
430K	300	361 A	433 A		
435K	350	414 A	497 A		
440K	400	477 A	572 A		

# Cable/Terminal/Torque Specifications

Installation should conform to the NEC Article 110 (NEC) (Requirements for Electrical Installations), all regulations of the Occupational Safety and Health Administration, and any other applicable national, regional, or industry codes and standards.

**Note:** The following ratings are guidelines and shall not be the sole determining factor of the lug or wire size used with the P9 ASD. Application-specific applicables, wire insulation type, conductor material, and local and regional regulations are but a few of the considerations when selecting the actual lug and wire type to be used with the P9 ASD.

**Note:** Cable/Terminal specifications are based on the rated current of the P9 ASD and **Do Not** include the 10% Service Factor.

**Note:** Use only 75° C copper wire/cable for motor and power connections.

For further installation information see the section titled [Installation and Connections](#) on pg. 10.

Table 11. 230-Volt P9 ASD Cable/Terminal/Torque Specifications.

Model Number VT130P9U	MCP Rating (Amps)	Wire/Cable Size		Lug Size Range		Terminal Board	Torque		
		AWG or kcmil						3Ø-Input	3Ø-Output
		Input/Output Power		Wire-Size/Lug-Capacity for Input/Output Power		TB1 – 4 Terminals			
		Recommended	Maximum	3Ø-Input	3Ø-Output	In-Lbs./Nm			
2010	15	14	10	14 to 8		20 (3-core shield) Torque to 5.3/0.6	11.5/1.3		
2015									
2025									
2035	30	10	12 to 8		17.7/2.0				
2055									
2080	50	8	8	8 to 3			21/2.4		
2110									
2160	75	6	3	12 to 1/0    4 to 1/0					50/5.7    53/6
2220	100	4							
2270	125	3							
2330	150	2	2	6 to 250    2 to 300		275/31    168/19			
2400	175	1/0	4/0						
2500	200	2/0							
2600	250	3/0							
2750	300	4/0							
210K	400	*3/0		6 to 250		275/31			
212K	500	*250	*250						

**Note:** (\*) Indicates that the item is one of a set of two parallel cables.

Table 12. 460-Volt P9 ASD Cable/Terminal/Torque Specifications.

Model Number VT130P9U	MCP Rating (Amps)	Wire/Cable Size		Lug Size Range		Terminal Board	Torque		
		AWG or kcmil						3Ø-Input	3Ø-Output
		Input/Output Power		Wire-Size/Lug-Capacity for Input/Output Power		TB1 – 4 Terminals			
		Recommended	Maximum	3Ø-Input	3Ø-Output	In-Lbs./Nm			
4015	15	14	10	14 to 8		20 (3-core shield) Torque to 5.3/0.6	11.5/1.3		
4025									
4035									
4055									
4080	20	12	8	12 to 8			17.7/2.0		
4110	30	10							
4160		50	8	10 to 4			21/2.4		
4220									
4270	75	4	3	8 to 3					
4330									
4400	100	3	2	12 to 1/0	4 to 1/0		50/5.7	53/6.0	
4500									
4600	125	2	4/0	6 to 250	1 to 300		275/31	168/19	
4750	175	1/0							
410K	200	2/0							
412K	250	4/0	*250	6 to 250			275/31		
415K	300	*1/0							
420K	400	*3/0							
425K	500	*250							
430K	600	*300	*350	4 to 350			375/42.4		
435K	700	*350							
440K	800	**250	**350	0 to 500	6 to 350				

**Note:** (\*) Indicates that the item is one of a set of two parallel cables.

**Note:** (\*\*) Indicates that the item is one of a set of three parallel cables.

# Short Circuit Protection Recommendations

Table 13. 230/240 and 400/480-Volt ASD Recommended Circuit Breaker Selection.

Model Number VT130P9U	HP	Continuous Output Current (Amps)	Circuit Breaker Part Number
2010	0.75	3.2	HLL36015
2015	1.0	4.2	
2025	2.0	6.8	
2035	3.0	9.6	HLL36025
2055	5.0	15.2	
2080	7.5	22.0	HLL36040
2110	10	28.0	HLL36050
2160	15	42.0	HLL36070
2220	20	54.0	HLL36090
2270	25	68.0	HLL36100
2330	30	80.0	
2400	40	104	HLL36125
2500	50	130	HLL36150
2600	60	154	JLL36200
2750	75	192	Contact TIC Customer Service
210K	100	248	
212K	125	312	
4015	1.0	2.1	HLL36015
4025	2.0	3.4	
4035	3.0	4.8	
4055	5	7.6	HLL36025
4080	7.5	11.0	
4110	10	14.0	HLL36040
4160	15	21.0	HLL36070
4220	20	27.0	
4270	25	34.0	HLL36090
4330	30	40.0	HLL36100
4400	40	52.0	
4500	50	65.0	HLL36125
4600	60	77.0	HLL36150
4750	75	96.0	JLL36200
410K	100	124	JLL36225
412K	125	156	JLL36250
415K	150	180	LIL36300
420K	200	240	
425K	250	302	LIL36400
430K	300	361	Contact TIC Customer Service
435K	350	414	
440K	400	477	Consult the NEC

# Index

## A

- AbFL, 70
- Abnormal Speed Settings, 41
- Acc/Dec 1 – 4 Settings, 45
- Acc/Dec Special, 45
- Accel/Decel 1 Settings, 35
- activate the battery backup, 24
- Alarm Prohibition, 39
- Alarms, 66, 68
- AM, 17, 19
- AM Output, 31
- AM/FM Output, 21
- Analog Filter, 42
- Analog Output Terminals, 36
- ASD Load, 31
- ASD OL (Overload) Trip, 31
- ASD Overload, 31, 74
- Atn, 67
- At-Trip Recorded Parameters, 75
- Auto Mode, 26
- Autotune Error, 72

## B

- Base Frequency Voltage, 41
- Battery Backup, 24
- battery life, 24

## C

- Cable/Terminal Specifications, 86
- Carrier Frequency, 45
- CC, 17
- CCA, 17
- Changed From Default, 40, 60
- Changed From Default Screen, 60
- Charge LED, 9, 12
- Circuit Breaker Configuration, 11
- Clearing a Trip, 75
- Clock Setup, 39
- CM1, 68
- CM2, 68
- Communication Adjustments, 52
- Communication Error, 71
- Communication Settings, 52
- Communications Setting Changes, 60

- Communications Settings, 52
- Compensation Frequency, 31
- Conduit Plate Dimensions, 76
- Connecting the ASD, 12
- Connection Diagram, 22
- Contrast, 40
- Control Power Under-Voltage, 74
- CPU Fault, 71
- Current/Voltage, 84
- Current/Voltage Specifications, 84
- Customer Support, 2

## D

- dbOn, 67
- DBR Load, 31
- DBR OL (Overload) Trip, 31
- DBR Overload, 31
- DC Bus Voltage, 31
- DC Injection Braking, 41
- Default Setting Changes, 60
- Direct Access, 38
- Discrete Input, 17, 21
- Discrete Input Terminals, 33
- Discrete Output, 17
- Display Parameters, 38
- Disposal, 3
- Drooping Control, 49
- Dynamic Braking, 41
- Dynamic Braking Resistor Over-Current, 73
- Dynamic Braking Resistor Overload, 74

## E

- E, 70
- E-10, 70
- E-11, 70
- E-12, 70
- E-13, 70
- E-17, 70
- E-18, 70
- E-19, 70
- E-20, 70
- E-21, 70
- E-22, 70
- E-23, 71



- E-24, 71
- E-25, 71
- E-26, 71
- EEP1, 71
- EEP2, 71
- EEP3, 71
- EEPROM Data Fault, 71
- EEPROM Fault, 71
- EF1, 71
- EF2, 71
- Electronic Operator Interface, 24
- Electronic Operator Interface Features, 26
- Emergency Off, 27, 70
- Emergency Off Settings, 41
- EMG, 68
- Enclosure Dimensions, 76
- Encoder Loss, 70
- EOI Command Screen, 30
- EOI Operation, 24
- EOI Remote Mounting, 25
- EPHI, 71
- EPHO, 71
- Equipment Inspection, 3
- ERR2, 71
- ERR3, 71
- ERR4, 71
- ERR5, 71
- ERR6, 71
- ERR7, 71
- ERR8, 71
- ERR9, 72
- ESC Key, 26
- ETN, 72
- ETN1, 72
- ETN2, 72
- ETN3, 72
- ETYP, 72
- Excitation Current, 32
- External Overheat, 73

## F

- F, 17, 18
- Fault, 66
- Fault Relay, 21
- Faults, 66
- Feedback (1 second), 32
- Feedback (inst), 32
- Feedback Settings, 49
- FLA, 17, 19
- FLA, B, and C Switching Relationship, 20
- Flash Memory Fault, 72
- FLB, 19

- FLC, 17, 19
- FM, 17, 19
- FM Output, 31
- Forward/Reverse Disable, 43
- FP, 17, 19
- FP Output, 21
- Frequency, 42
- Frequency at Trip, 31
- Frequency Command Mode, 29
- Frequency Command Screen, 28, 59
- Frequency Control, 46
- Frequency Reference, 31
- Frequency Setting, 29
- Frequency Settings, 35
- Fundamental, 35

## G

- Gate Array Fault, 71
- General Safety Information, 1
- Ground Fault, 71

## H

- Hand Mode, 26
- Hand/Auto Key, 26
- Handling and Storage, 3

## I

- I/O and Control, 17
- I/O Circuit Configurations, 21
- IICC, 17, 22
- Important Notice, 3
- Input Phase Failure, 71
- Input Power, 32
- Input Special Functions, 36
- Input Terminal Delays, 36
- Installation and Connections, 10
- Installation Notes, 10
- Installation Precautions, 4

## J

- Jog Settings, 43
- Jump Frequencies, 46

## L

- LCD Character/Font Information, 27

LCD Screen, 26, 28  
Lead Length Specifications, 16  
LED Character/Font Information, 27  
LED Screen, 26, 27  
LED/LCD Screen Information, 27  
Line Power Switching, 37  
Lockout, 57  
Low Suction/No Flow Cut Off, 70  
Low Suction/No-Flow Cut Off, 35  
Low-Current, 71  
Low-Current Settings, 41  
Lug Size, 86, 87

## M

Main Monitor, 40  
Main Monitor Selections, 33  
Manual Torque Limit Settings, 47  
MCP Rating, 86, 87  
Mode Key, 26  
MOFF, 68  
Monitor Mode, 31  
Monitor Screen, 28  
Motor Connection Diagram, 13  
Motor Load, 31  
Motor OL (Overload) Trip, 31  
Motor Overload, 74  
Motor Overload Real, 31  
Motor Set 1, 35  
Motor Set 2, 46  
Motor Set 3, 47  
Motor Set 4, 47  
Motor Settings, 46  
Motor/ASD Setup, 34  
Mounting the ASD, 11  
My Function, 50  
My Function Monitor, 52

## N

NERR, 72

## O

O1A/B, 17  
O2A/B, 19  
OC, 68  
OC1, 72  
OC1P, 72  
OC2, 73  
OC2P, 73  
OC3, 73

OC3P, 73  
OCA1, 73  
OCA2, 73  
OCA3, 73  
OCL, 73  
OCR, 73  
OH, 68, 73  
OH2, 73  
OJ, 68  
OL1, 74  
OL2, 74  
OLI, 69  
OLM, 69  
OLR, 69, 74  
OP, 69  
OP1, 74  
OP2, 74  
OP3, 74  
Operation (Hand), 59  
Operation Mode, 54  
Operation Panel Parameters, 46  
Operational and Maintenance Precautions, 9  
OT, 69, 74  
OUT1, 17, 19  
Out1 Out2 FL, 33  
OUT1/OUT2 Output, 21  
OUT2, 19  
Output Current, 31  
Output Disconnect, 8  
Output Phase Failure, 71  
Output Power, 32  
Output Terminals, 38  
Output Voltage, 31  
Over-Current During Acceleration, 72  
Over-Current During Deceleration, 73  
Over-Current During Run, 73  
Overheat, 73  
Overheat During Acceleration, 72  
Overheat During Deceleration, 73  
Overheat During Run, 73  
Overload, 41  
Override Control, 49  
Over-Speed, 70  
Over-Torque, 74  
Over-Torque Parameters, 41, 42  
Over-Voltage During Acceleration, 74  
Over-Voltage During Deceleration, 74

## P

P24, 17, 19  
P24 Output, 21  
PA/+, 12

- Part Numbering Convention, 76
- Password, 57
- Past Trip 1, 32
- Past Trip 2, 32
- Past Trip 3, 33
- Past Trip 4, 33
- Pattern Group Cycle, 32
- Pattern Group Number, 32
- Pattern Group Preset, 32
- Pattern Run, 54
- Pattern Time, 32
- PC/-, 12
- PG Settings, 49
- PG Type/Connection Error, 70
- Phase Loss, 42
- PID Feedback, 32
- PM Motor, 47
- PO, 12
- POFF, 69
- Power Connections, 12
- PP, 17, 19
- PP Output, 21
- Preset Speeds, 43
- Primary Menus, 28
- Program Menu, 28
- Program Mode Menu Navigation, 34
- Prohibition, 38
- Protection, 41
- PtSt, 69

## Q

- Qualified Personnel, 2

## R

- R, 17, 18
- R/L1, 12
- RAM Fault, 71
- Reach Settings, 38
- Read Error, 71
- real-time clock, 75
- Real-Time Clock Setup, 39
- RES, 17, 18
- Reset, 39
- Restore User Settings, 61
- Retry/Restart, 42
- ROM Fault, 71
- Root Menu Mapping, 29
- Root Menus, 29
- Rotary Encoder, 26
- RR, 17, 18, 32

- RR Input, 21
- Run Key, 26
- Run Time, 31
- RX, 17, 18, 32
- RX Input, 21
- RX2, 32

## S

- S/L2, 12
- S1, 17, 18
- S2, 17, 18
- S3, 17, 18
- S4, 17, 18
- Save User Settings, 61
- SEAL, 74
- Sealing Water Error, 74
- Setpoints, 47
- Short Circuit Protection, 88
- Sink, 20
- Sink/Source Setting Error, 70, 71
- Source, 20
- SOUT, 74
- Special, 45
- Special Parameters, 46
- Special Protection Parameters, 42
- Speed Error, 70
- Speed Reference Setpoints, 43, 44
- ST, 17, 18
- Stall, 42
- Standard Mode Selection, 35
- Startup and Test, 23
- Stop-Reset Key, 27
- SU+, 17, 19
- System Configuration and Menu Options, 29
- System Grounding, 14
- System Integration Precautions, 7
- System Operation, 59

## T

- T/L3, 12
- Terminal, 36
- Terminal Board, 17, 20
- Terminal Descriptions, 18
- Torque, 32, 47
- Torque Control, 48
- Torque Current, 32
- Torque Limit Settings, 48
- Torque Reference, 32
- Torque Speed Limiting, 48
- Trace, 40

Transducer Setup, 34  
Trip Code, 32  
Trip History, 75  
Trip History (read-only), 39  
trip records are retained, 75  
Trip Settings, 42  
Trouble Shooting, 66  
Type Reset, 39  
Typeform Error, 72

## U

U/T1, 12  
UC, 69  
UL 1995, 76  
Under-Voltage/Ridethrough, 42  
UP/DOWN Frequency Functions, 43  
UP1, 74  
UP2, 74  
U-Phase Over-Current, 73  
User Notification Codes, 67  
Utilities, 38

## V

V/f 5-Point Setting, 45  
V/I, 32, 43  
V/I Input, 21  
V/I Settings, 43  
V/T2, 12  
Vector Motor Model, 47  
Version, 38  
Viewing Trip Information, 75  
VIRTUAL LINEAR PUMP, 34  
VLP Run External Devices, 34  
VLP Sealing Water, 35  
VLP Settings, 34  
VLP Setup Wizard, 34  
VLP Sleep Timer, 34  
VLP Start and Stop Points, 34  
V-Phase Over-Current, 73

## W

W/T3, 12  
Warranty Card, 2  
W-Phase Over-Current, 73

# **TOSHIBA**

TOSHIBA INTERNATIONAL CORPORATION  
INDUSTRIAL DIVISION

13131 West Little York Road, Houston, TX 77041-5807

US (800) 231-1412 CAN (800) 872-2192 MEX 01 (800) 527-1204

FAX: (713) 466-8773

<http://www.toshiba.com/ind/>

Printed in the U.S.A.